

# Universal Tube Output Stage Installation Manual

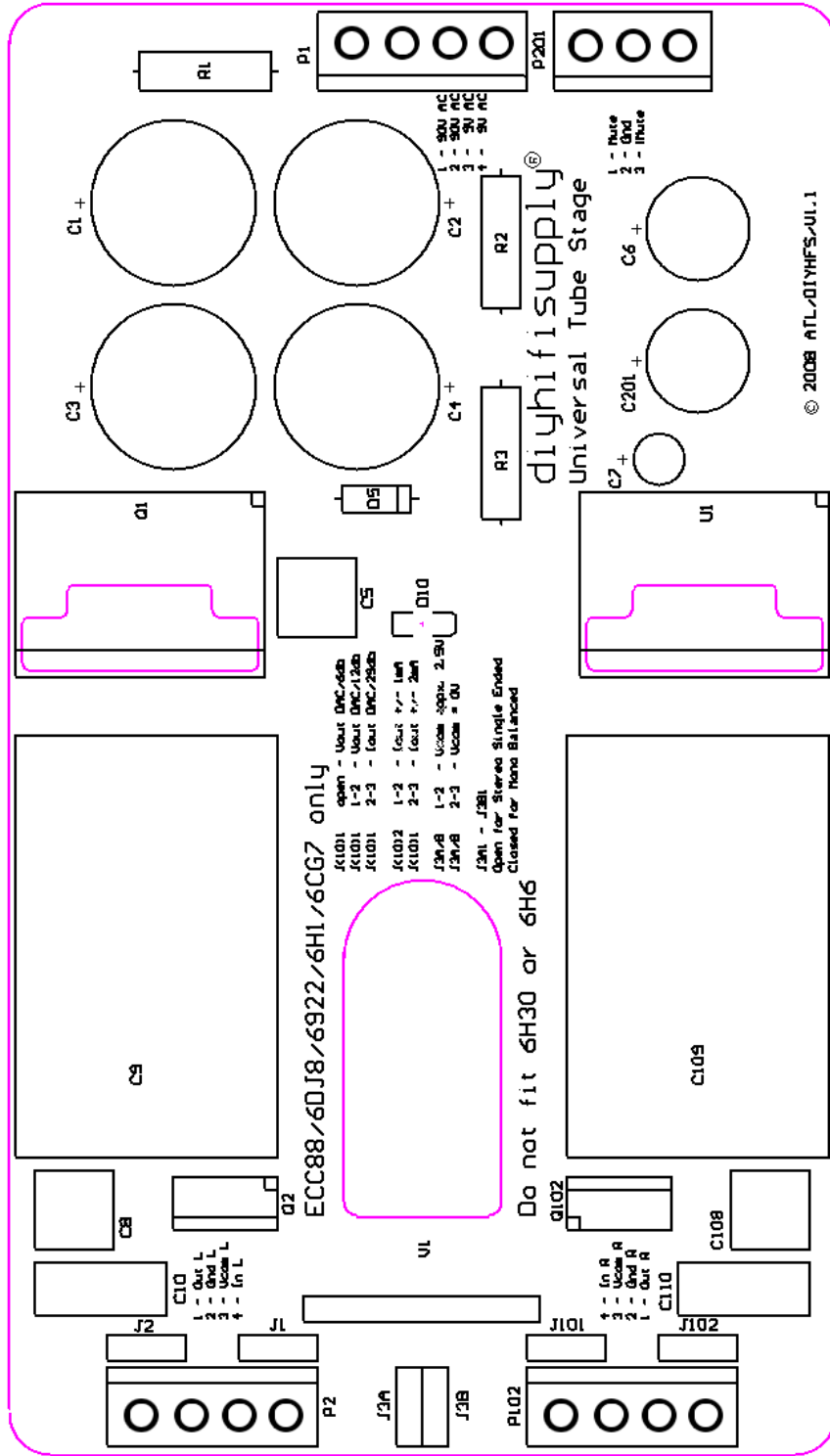

## Table of Contents

Universal Tube Output Stage Installation Manual.....	1
Specifications:.....	7
Mechanical:.....	7
Electrical Performance: .....	7
1 – Power Supply Wiring .....	8
Muting.....	8
2 – Output Connector Wiring .....	9
2.1 – Stereo Single Ended Connection.....	9
2.2 – Stereo Balanced Connection.....	10
3 – Input Wiring and Module Configuration.....	11
3.01 – Settings and Input wiring for current output DAC, stereo, single ended, 1mA full scale current, 0V reference voltage.....	12
3.02 – Settings and Input wiring for current output DAC, stereo, single ended, 2mA full scale current, 0V reference voltage.....	13
3.03 – Settings and Input wiring for current output DAC, dual mono, single ended, 1mA full scale current, 0V reference voltage.....	15
3.04 – Settings and Input wiring for current output DAC, dual mono, single ended, 2mA full scale current, 0V reference voltage.....	16
3.05 – Settings and Input wiring for current output DAC, balanced mono DAC's, balanced output, 1mA full scale current, 0V reference voltage.....	17
3.06 – Settings and Input wiring for current output DAC, balanced mono DAC's, balanced output, 1mA full scale current, 0V reference voltage.....	18
3.07 – Settings and Input wiring for current output DAC, stereo, single ended, 1mA full scale current, ~2.5V reference voltage.....	19
3.08 – Settings and Input wiring for current output DAC, balanced Stereo DAC's, balanced output, 1mA full scale current, 2.5V reference voltage.....	20
3.09 – Settings and Input wiring for current output DAC, balanced Stereo DAC's, balanced output, 4mA full scale current, 2.5V reference voltage.....	21
3.10 – Settings and Input wiring for current output DAC, balanced Stereo DAC's, balanced output, 4mA full scale current, 0V reference voltage.....	22
3.11 – Settings and Input wiring for voltage output DAC, stereo, single ended, 1...1.5 VRMS full scale output voltage, 0V reference voltage.....	23
3.12 – Settings and Input wiring for voltage output DAC, stereo, single ended, 1...1.5 VRMS full scale output voltage, 2.5V reference voltage.....	24
3.13 – Settings and Input wiring for voltage output DAC, stereo, balanced output, 2...3 VRMS full scale output voltage, 2.5V reference voltage.....	26
3.14 – Settings and Input wiring for single ended stereo output from voltage output DAC, stereo, balanced output, 2..3 VRMS full scale output voltage, 2.5V reference voltage.....	28
4 – Other applications of the Universal Tube Output Stage .....	29
4.1 – Settings and Input wiring for use as SE Linestage 6db Gain.....	30
4.2 – Settings and Input wiring for use as SE Linestage 12db Gain.....	31
4.3 – Settings and Input wiring for use as Balanced Linestage 6db Gain.....	32
4.4 – Settings and Input wiring for use as Balanced Linestage 12db Gain.....	33
4.5 – Settings and Input wiring for use as simple single ended stereo RIAA equalisation preamplifier.....	34

## ***Introduction and Overview***

The diyhifisupply® Universal Tube Output Stage has been designed to offer a State of the Art tube amplification stage, mainly intended to be applied to CD-Players, DVD-Players and DA-Convertors to completely replace the original solid state analogue circuit.

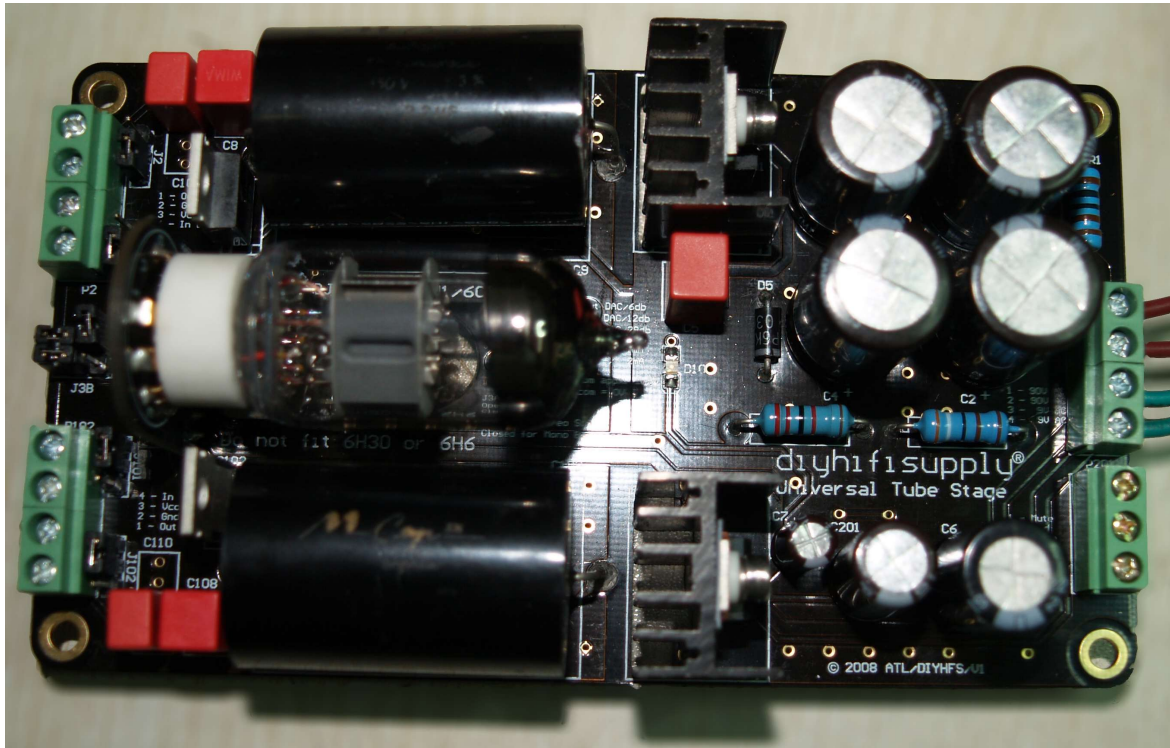

Additional applications include the use as Line Preamp with 6dB or 12dB gain.

The module can also be used as low noise, high gain (gain appx. 30db) amplification block for low level applications such as RIAA pre-amplification stages and as microphone or instrument amplifier.

Using one module we have either a stereo single-ended input and output (two independent channels) or a mono balanced input and output (single balanced channel). If a stereo balanced input and output are required two modules must be used.

Each configuration can be used either as single ended in/out stereo for one PCB or as balanced in/out per PCB.

If using a balanced output DAC with a single ended input Tube output an additional resistor or resistor/capacitor needs to be added externally to the tube PCB.

All DAC types listed below names the most commonly encountered types, but is by no means exhaustive.

**Some examples:**

- 1) Analog stage for current output DAC – 2V out for 0dbfs with 1mA or 2mA full scale current, can be configured for DAC's having their output referenced to either ground (TDA1541, PCM56/63/1702/1704, AD1856/1862/1865) or an arbitrary reference voltage of 2 – 3V (TDA1543/1545, PCM1738,AD1853 and many others) , < 100R output impedance.
  
- 2) Analog stage for voltage output DAC – 2V out for 0dbfs with 1V or 0.5V full scale voltage, can be configured for DAC's having their output referenced to either ground (CS4328) or an arbitrary reference voltage of 2 – 3V (CS4329/9X; PCM1716/1728/1732/1741; AKM4393/4394/4395; AD1852/1854/1855; NPC SM5872/5865/5866 et al) , < 100R output impedance.
  
- 3) General high level gainstage – 6db gain, inverting output, >400KOhm input Impedance, < 100R output impedance
  
- 4) General high level gainstage – 12db gain, inverting output, >200KOhm input Impedance, < 100R output impedance
  
- 5) General low level gainstage (Microphone, Phono, Tapehead etc.) with around 30db gain and > 40KOhm input impedance, < 100R output impedance

Some possible applications past the use as line stage (obvious) or DAC output stage (equally obvious):

Single Ended MM Phono Stage – 2 Modules, add a RIAA EQ of 10K or higher impedance at low frequencies (calculator @ <http://kabusa.com/riaa.htm>) or 10K RLC EQ... (add pre-pre or MC stepup TX for MC)

Balanced MM Phono Stage – 4 Modules, add a balanced RIAA EQ of 10K or higher impedance at low frequencies (calculator @ <http://kabusa.com/riaa.htm>) or 10K RLC EQ... (add pre-pre or MC stepup TX for MC)

Single Ended Tape Head Stage – 2 Modules, add a NAB etc. EQ of 10K or higher impedance at low frequencies (calculator @ <http://kabusa.com/riaa.htm>) or 10K RLC EQ...

Balanced Tape Head Stage – 4 Modules, add a balanced NABetc. EQ of 10K or higher impedance at low frequencies (calculator @ <http://kabusa.com/riaa.htm>) or 10K RLC EQ...

Classic high gain 1-Channel transformer coupled Microphone Preamplifier using 1:4/5 input transformer and 5/4:1 transformer balanced output with level control between stages – 1 Modules – maximum gain ~60db.

Classic high gain 2-Channel transformer coupled Microphone Preamplifier using 1:4/5 input transformer and 5/4:1 transformer balanced output with level control between stages – 2 Modules – maximum gain ~60db.

Classic low gain 2-Channel transformer coupled Microphone Preamplifier using 1:4/5 input transformer and transformerless balanced output (10K load) – 2 Modules – maximum gain ~40db.

Classic high gain 2-Channel transformer coupled Microphone Preamplifier using 1:4/5 input transformer and transformerless balanced output (10K load) with level control between stages – 4 Modules – maximum gain ~72...75db.

Input and Summing Amplifier in a classic tube mixer, for example, a 6 – 2 mixer could be build using 6 Microphone transformers(plus instrument input jacks), 3 tube stage modules for inputs, suitable volume and pan control faders/potentiometers per chnnel and one tube output module with 4/5:1 stepdown output transformers fo balanced output... Maximum gain in to out using 1:4/4:1 transformers is around 60db.

For ease of application all connections on the Universal Tube Output Stage are provided as screw terminals and all configurations are handled by gold-plated jumpers, so no soldering is required on the actual Universal Tube Output Stage Module.

For those desiring soldered connections instead we recommend to either unsolder the screw terminals and solder the wires in the holes thus available or to simply solder the wires to the solder pads below the PCB.

Equally, for those wishing a soldered configuration instead of jumpers simple solder bridges can be soldered across the jumper pins below the PCB.

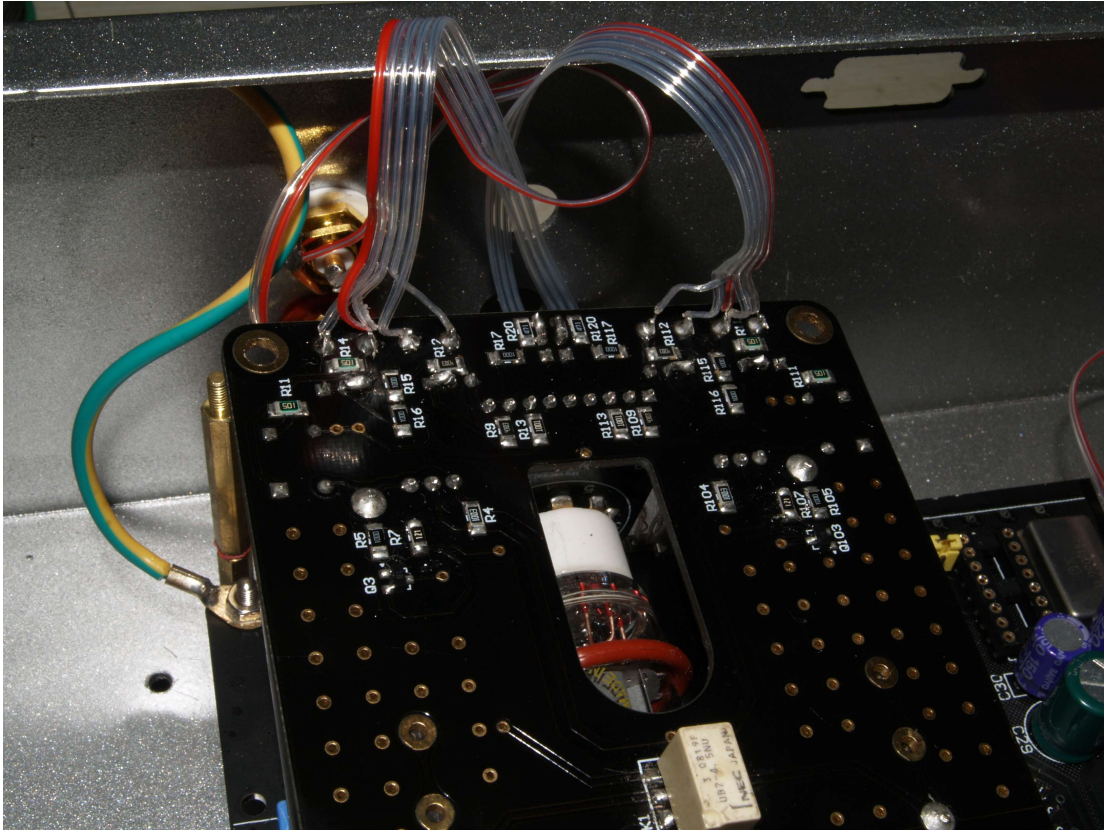

In the following Manual the application of the Universal Tube Output Stage is broken down into three distinct sections.

Section one covers the connections of the included power supply transformer while section two covers the connections of the output sockets to the module.

Section three covers the different arrangements of the Input connections and the jumper configuration to suit the various available DAC Chips and the other applications.

## ***Specifications:***

### **Mechanical:**

Tube PCB with 10mm Standoffs (10mm standoffs are required and 10mm clearance must be present below the PCB):

140mm deep

80mm wide

45mm high

Fixing holes in the four corners on a 71mm X 131mm rectangle. Fixing holes require M3 or equivalent screws.

Mains transformer:

76mm diameter

40mm high

Fixing with either central M4/M5 bolt or via 4 racetrack shaped 8mm X 5mm Holes centered on a 60mm square.

This means for the mains transformer to fit at least 40mm clearance above it is required, the tube stage needs 45mm.

### **Electrical Performance:**

(example only as will vary by implementation):

measurements lout DAC Mode (=30db gain)

referenced to 2V RMS, Saratov (Reflector/Sovtek) 6N23 fitted

Measurements vary with different tubes fitted

specifications:

- S/N- > 100dbA (approx 5nv/hz).
- THD- <0.15% (<0.1% typical); <1%THD (10Vout, 100K load)
- 20Hz – 20KHz (< -0.5db with IHF 10K/1nf load)
- Output Impedance <100 Ohm
- Can use 6cg7, 6N11,ECC 88, 6DJ8, 6922, 6H1 only

## 1 – Power Supply Wiring

If your local power supply is in the range of 100V to 120V AC wire up the mains transformer as shown below.

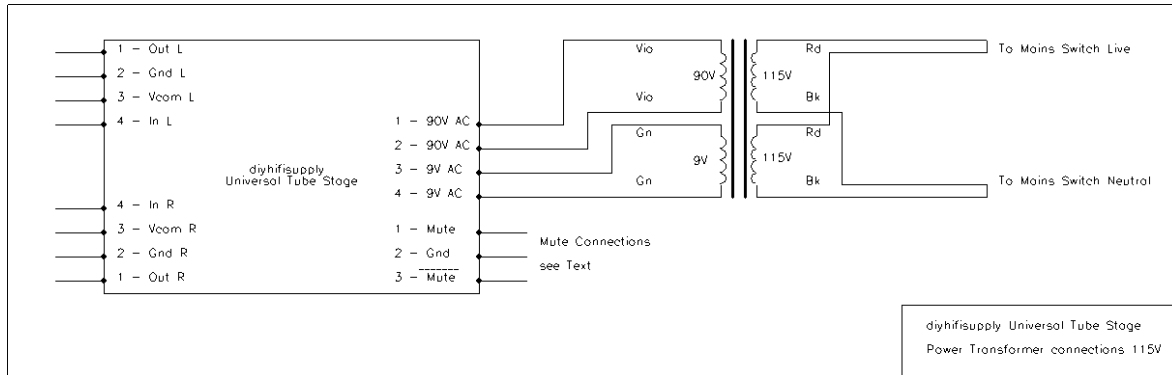

If your local power supply is in the range of 220V to 240V AC wire up the mains transformer as shown below.

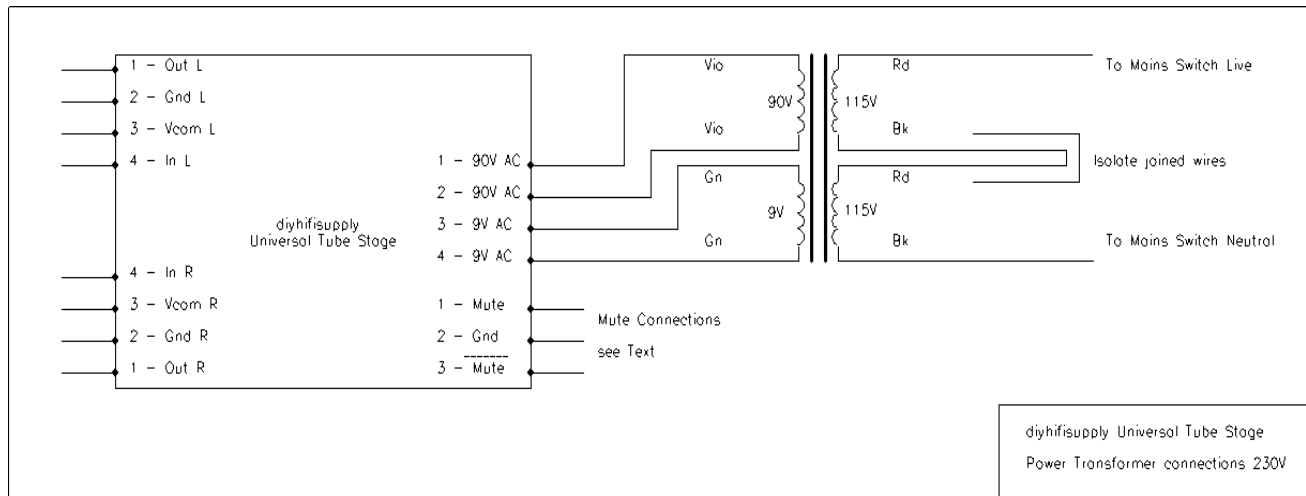

## Muting

The Universal Tube Output Stage is fitted with a relay based muting circuit (shunt type so it is completely disconnected when unmated) which also performs a turn-on delay.

For CD-Players that produce unwanted noises etc. between tracks it may be desirable to use this circuit to mute the signal the same way the original analogue stage did.

As this requires you to find the actual logic signal that controls the muting in the original equipment this is quite advanced and no simple guidance is possible. You will most likely require a copy of the service manual and the ability to read the schematics within.

The Universal Tube Output Stage can accept mute signal that either mute when a “High” signal is present (use the connection labeled Mute) or that can mute when a “Low” Signal is present (use the connection labeled /Mute).

## 2 – Output Connector Wiring

The Universal Tube Output Stage can be connected either for stereo single ended connections or with two modules for stereo balanced connections.

### 2.1 – Stereo Single Ended Connection

Shown below are the connections that need to be made from the RCA sockets to the Universal Tube Output Stage for a stereo single ended arrangement.

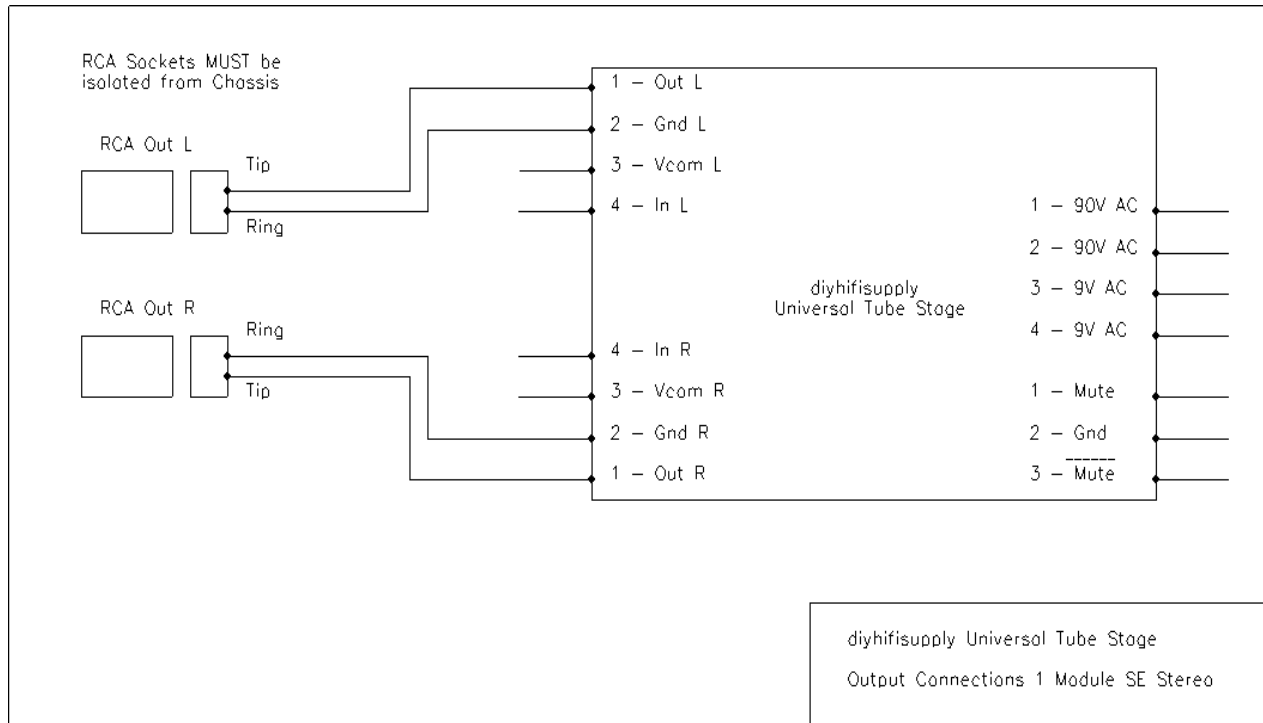

Depending on the RCA connectors used you may have to solder the wires to the RCA Sockets.

It is important that the RCA sockets are mounted such the sockets metal shell does not make contact with the Chassis.

## 2.2 – Stereo Balanced Connection

Shown below are the connections that need to be made from the XLR and (optionally) RCA sockets to the Universal Tube Output Stage for a stereo balanced arrangement.

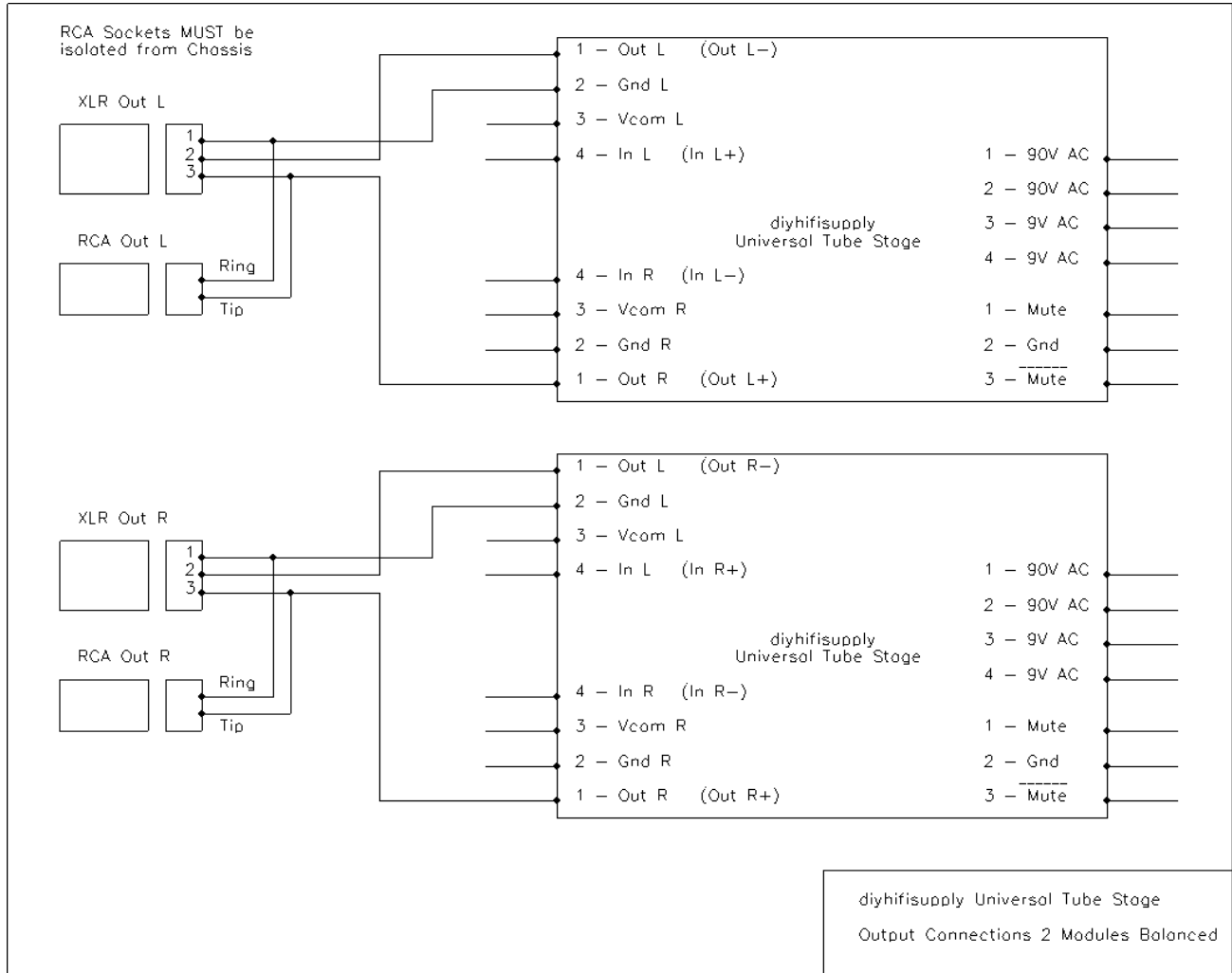

Depending on the XLR & RCA connectors used you may have to solder the wires to the XLR and RCA sockets.

It is important that the RCA sockets are mounted such the sockets metal shell does not make contact with the Chassis.

The metal shell of XLR connectors is designed to contact the chassis for shielding and hence it can and should make contact with the chassis.

### **3 – Input Wiring and Module Configuration**

The Universal Tube Output Stage can be connected and configured in many different configurations to allow for virtually all DAC's made to be connected correctly.

In order to select the correct input wiring and jumper setting you need to determine the actual part number of the DAC Chip fitted to your CD-Player, DVD-Player or DA-Converter. If your DAC Chip is listed in the Appendix you only need to select the correct page for this DAC.

You will still need to determine the actual Pins on the DAC Chip that carry the output signal, analogue ground and if present reference voltage. You will need to tap off these DAC Chip pins and connect them to the Universal Tube Output Stage.

If the DAC Chip has a so-called “voltage” output you can keep the original solid state analogue stage connected and run it and the Universal Tube Output Stage in parallel.

If the DAC Chip has a so-called “current” output you must disconnect the original solid state analogue stage from the DAC. This usually means cutting away the traces connecting to the current output pins.

As can be seen from the above, one of the key distinguishing marks of DAC Chips for our application is the presence of Voltage or Current outputs. Usually current outputs tend to sound better as there is no additional circuitry build into the DAC Chip to convert the current from the actual DAC into Voltage. Some DAC Chips have the circuitry for current to voltage conversion on chip, but allow the user to access the current output. In this case using the current output is preferred.

Other items of concern when selecting the correct connection and settings are if the DAC Outputs actually are referenced to Analogue Ground (0V DC on the DAC output pins) or if they are referenced to a so-called “reference voltage” (around 2.5V DC offset on the DAC output pins).

Of final concern is if the DAC used has single ended or balanced outputs. If the DAC has only Single Ended outputs it is not possible to get a balanced output signal.

Conversely, DAC's that have a balanced output can generally be connected in single ended mode with little or no complications.

In the following we will cover individual configurations for various DAC Chip Structures.

Wherever possible a list of known DAC's conforming to this scheme is given.

Known means they are known to have been manufactured at some time and are documented in the public domain to have technical data and design features placing them into the group of DAC's using this scheme. It does not imply that the particular combination of DAC and Universal Tube Output Stage has been tested with this type of DAC.

### 3.01 – Settings and Input wiring for current output DAC, stereo, single ended, 1mA full scale current, 0V reference voltage

Known examples of DAC's requiring these settings are Burr Brown PCM1700 as well as Analog Devices AD 1865.

This type of DAC requires the following jumper settings:

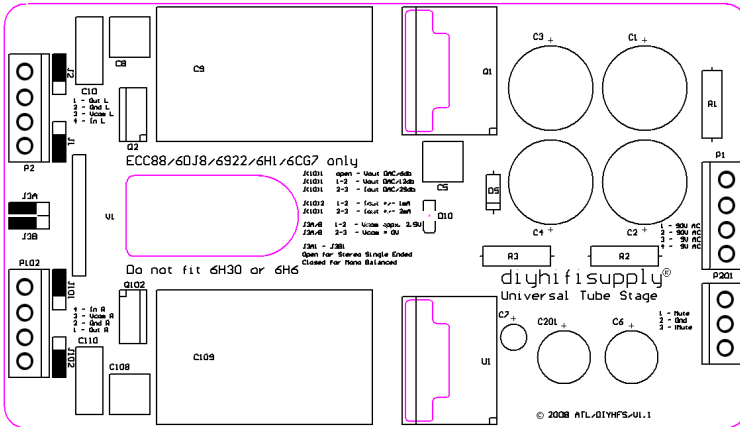

The input connections should follow the Scheme shown underneath:

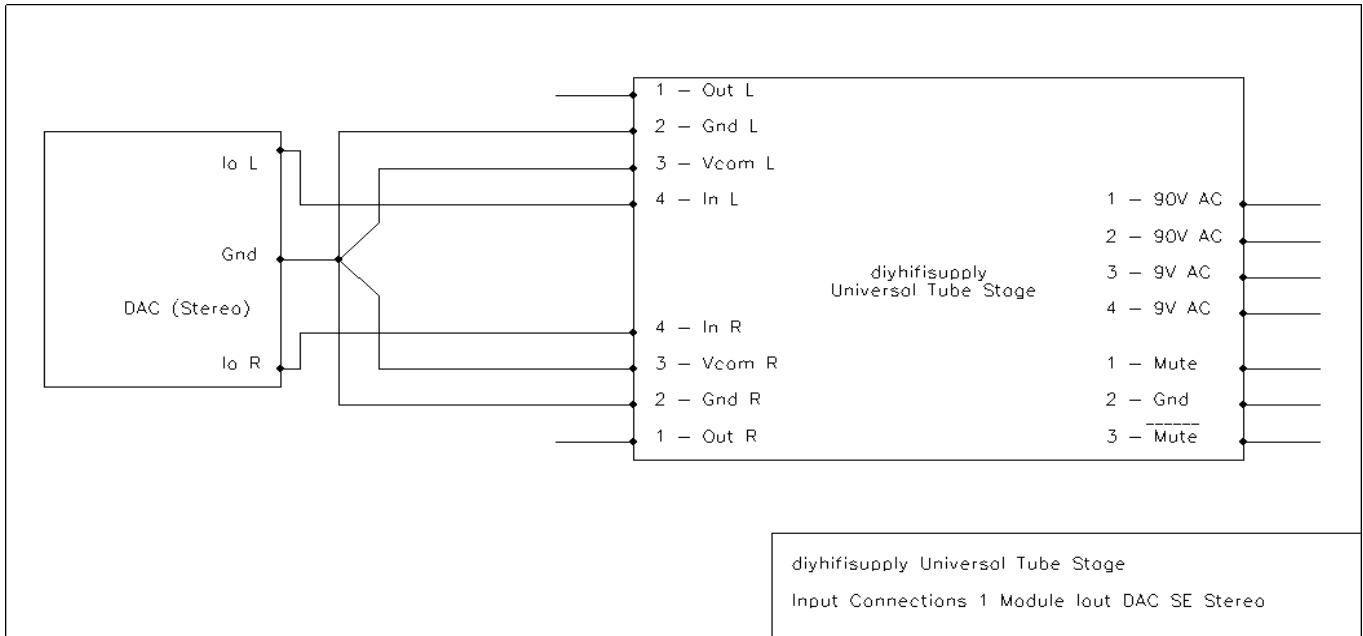

All Ground connections and the Vcom connections must be made to the DAC's Analogue Ground Pin.

### 3.02 – Settings and Input wiring for current output DAC, stereo, single ended, 2mA full scale current, 0V reference voltage

A known example of a DAC requiring these settings is the Philips TDA1541/TDA1541A.

This type of DAC requires the following jumper settings:

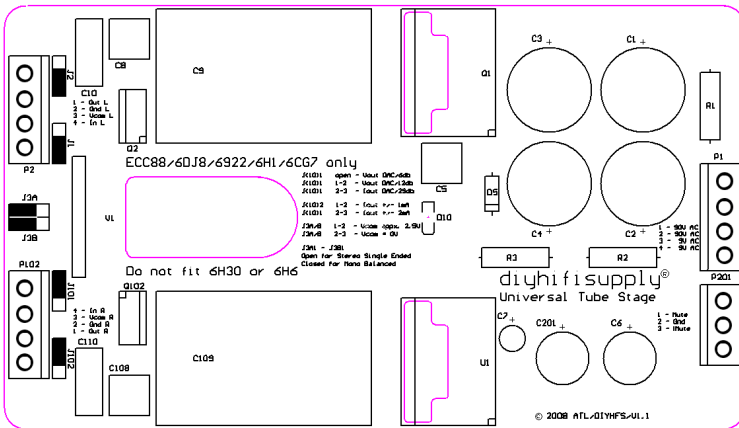

The input connections should follow the Scheme shown underneath:

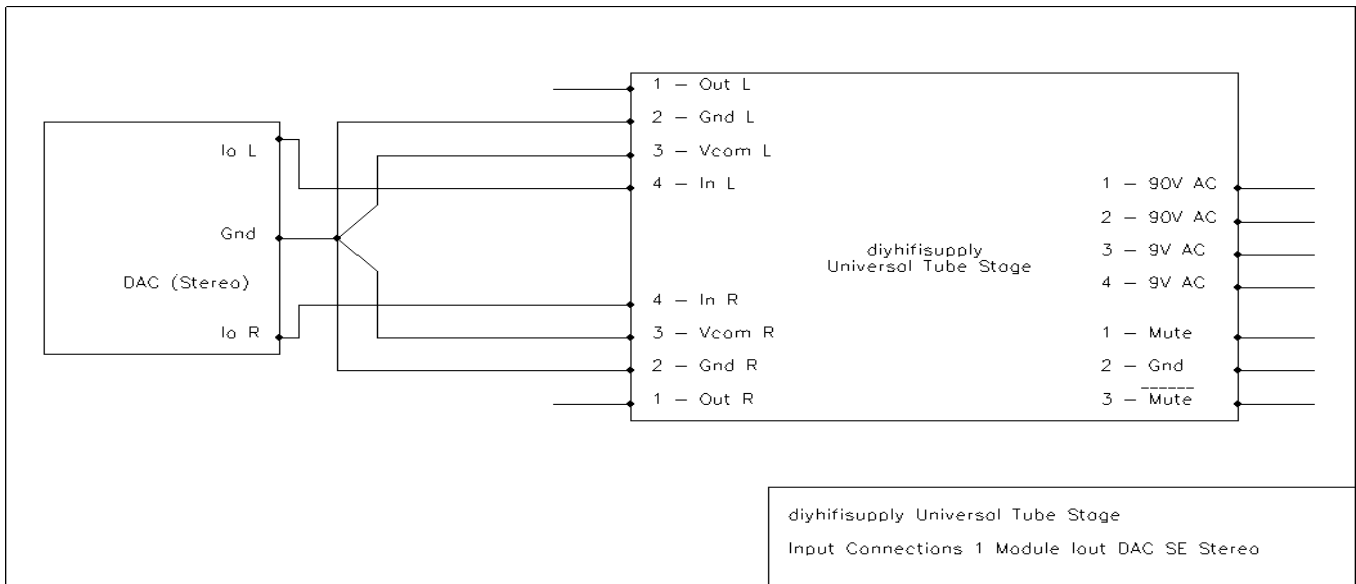

All Ground connections and the Vcom connections must be made to the DAC's Analogue Ground Pin.

The TDA1541(A) is listed in the Datasheet as follows:

**PINNING**

1	LE/WS*	latch enable input word select input
2	BCK*	bit clock input
3	DATA L/DATA*	data left channel input data input (selected format)
4	DATA R/SYS*	data right channel input system clock input
5	GND (A)	analogue ground
6	AOR	right channel output
7	DECOU	decoupling
8	DECOU	
9	DECOU	
10	DECOU	
11	DECOU	
12	DECOU	
13	DECOU	
14	GND (D)	digital ground
15	V <sub>DD2</sub>	-15 V supply voltage
16	n.c.	not connected
17	n.c.	
18	DECOU	decoupling
19	DECOU	
20	DECOU	
21	DECOU	
22	DECOU	
23	DECOU	
24	DECOU	left channel output
25	AOL	
26	V <sub>DD1</sub>	-5 V supply voltage
27	OB/TWC*	mode selection input
28	V <sub>DD</sub>	+5 V supply voltage

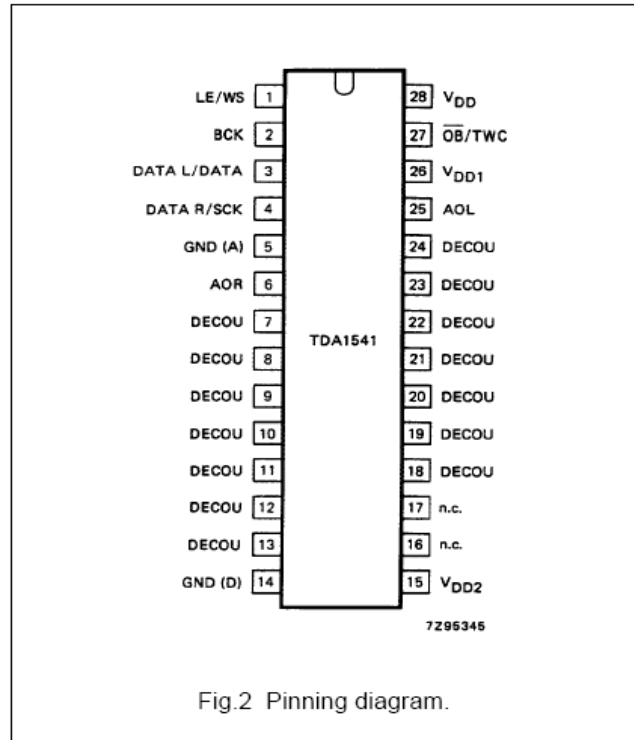

From this we derive that Pin 5 is “Analogue Ground”, Pin 6 is “Right Channel (Current) Out” and Pin 25 is “Left Channel (Current) Out”.

So we need to disconnect all traces from Pin 6 and Pin 25.

Then we need to connect Pin 25 to the In L connection on the Universal Tube Output Stage and Pin 6 to the In R connection.

The connections from Gnd L, Gnd R, Vcom L and Vcom R on the Universal Tube Output Stage need to be made all to Pin 5 of the TDA1541, preferably using individual wires.

### 3.03 – Settings and Input wiring for current output DAC, dual mono, single ended, 1mA full scale current, 0V reference voltage

Known examples of DAC's requiring these settings are Burr Brown PCM56, PCM58, PCM1702 & PCM1704 as well as Analog Devices AD 1851, AD1856, AD1860, AD1861 & AD1862.

This type of DAC requires the following jumper settings:

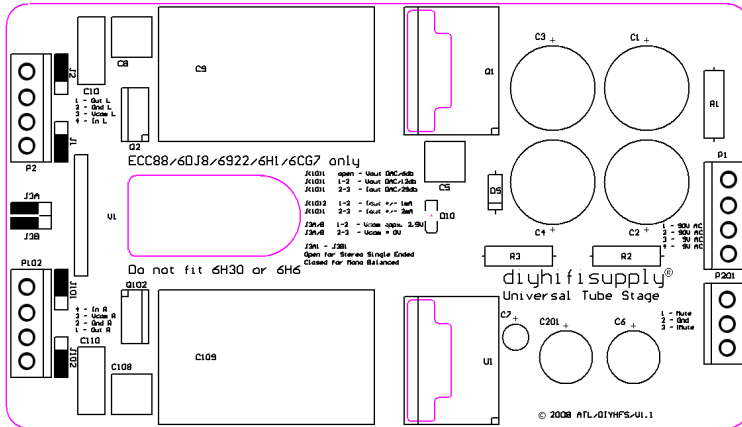

The input connections should follow the Scheme shown underneath:

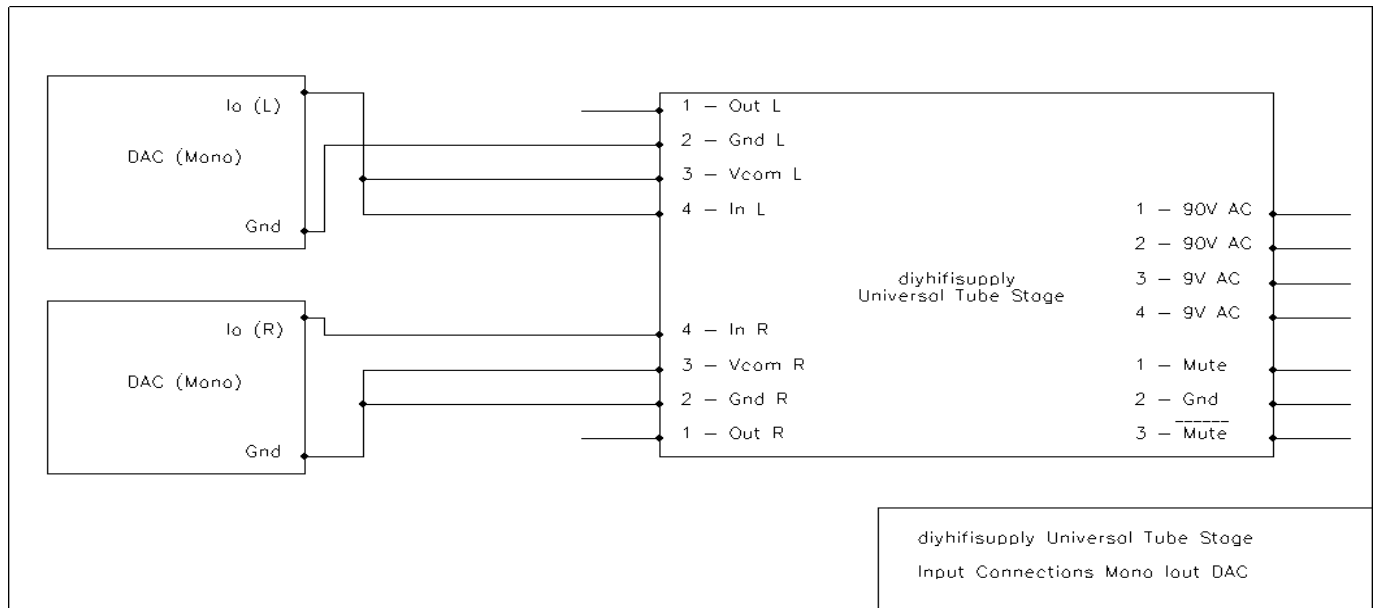

All Ground connections and the Vcom connections must be made to the respective channels DAC's Analogue Ground Pins.

### 3.04 – Settings and Input wiring for current output DAC, dual mono, single ended, 2mA full scale current, 0V reference voltage

A known example of a DAC requiring these settings is the Burr Brown PCM63.

This type of DAC requires the following jumper settings:

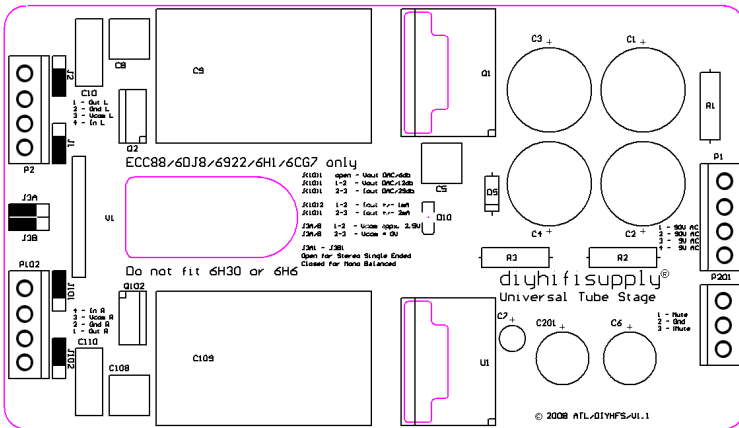

The input connections should follow the Scheme shown underneath:

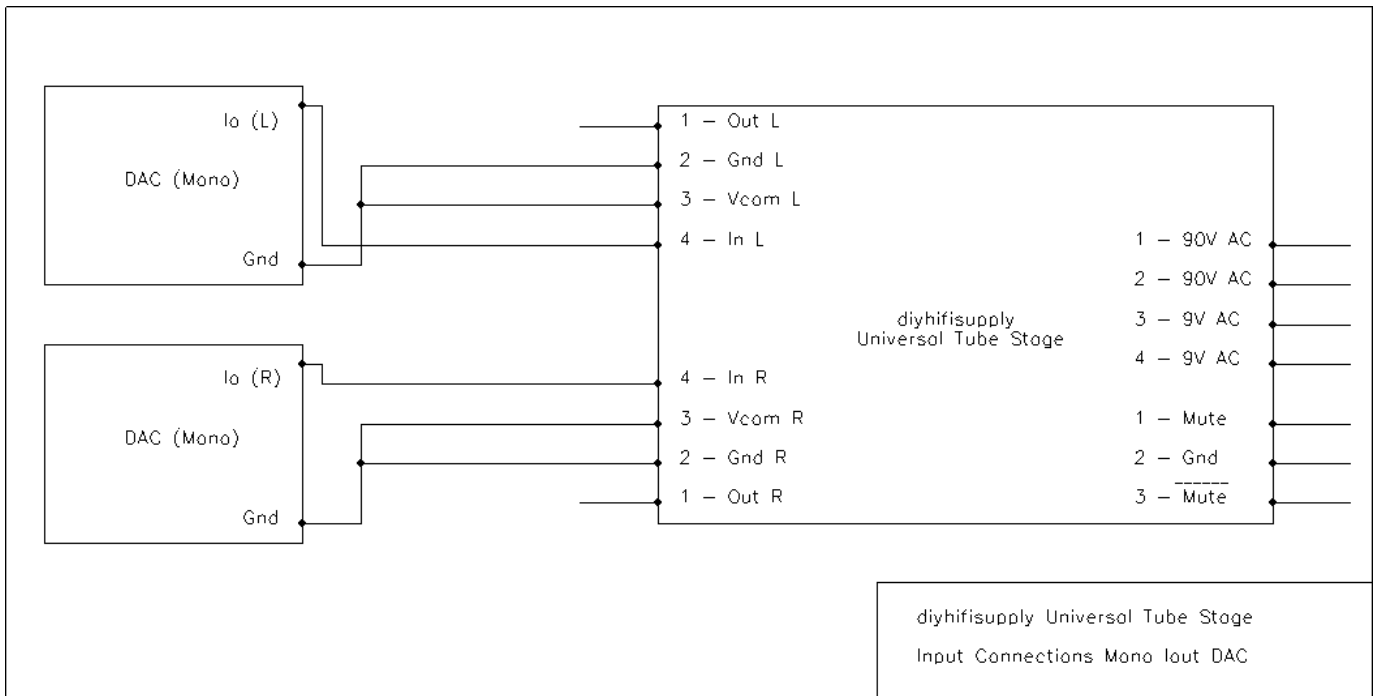

All Ground connections and the Vcom connections must be made to the respective channels DAC's Analogue Ground Pins.

### 3.05 – Settings and Input wiring for current output DAC, balanced mono DAC's, balanced output, 1mA full scale current, 0V reference voltage

Players and DA Convertors where four DAC's are operated in balanced mode require these settings and wiring. The types of DAC Chips applicable are Burr Brown PCM56, PCM1702 & PCM1704 as well as Analog Devices AD1856, AD1861 & AD1862.

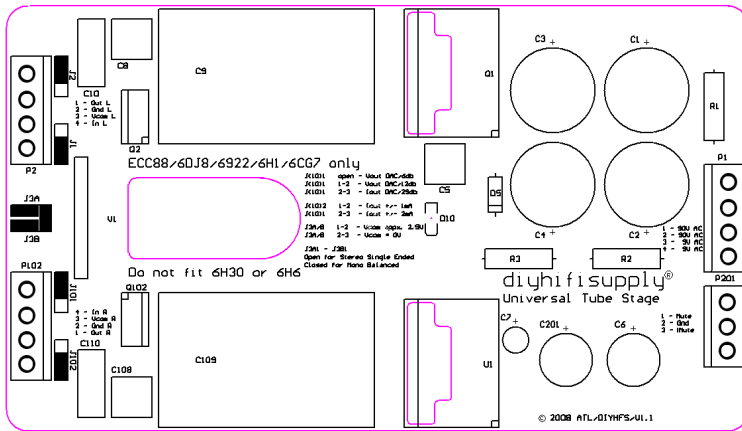

The input connections should follow the Scheme shown underneath:

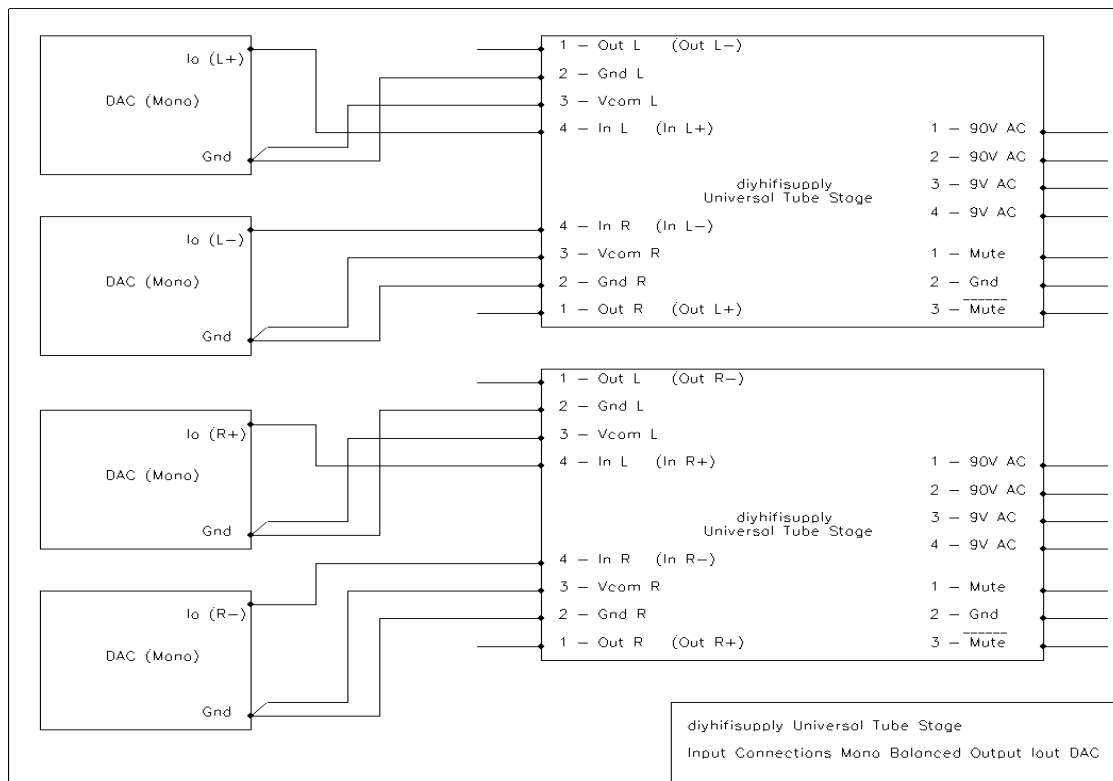

All Ground connections and the Vcom connections must be made to the respective channels DAC's Analogue Ground Pins.

### 3.06 – Settings and Input wiring for current output DAC, balanced mono DAC's, balanced output, 2mA full scale current, 0V reference voltage

Players and DA Convertors where four DAC's are operated in balanced mode require these settings and wiring. The types of DAC Chips applicable are Burr Brown PCM63.

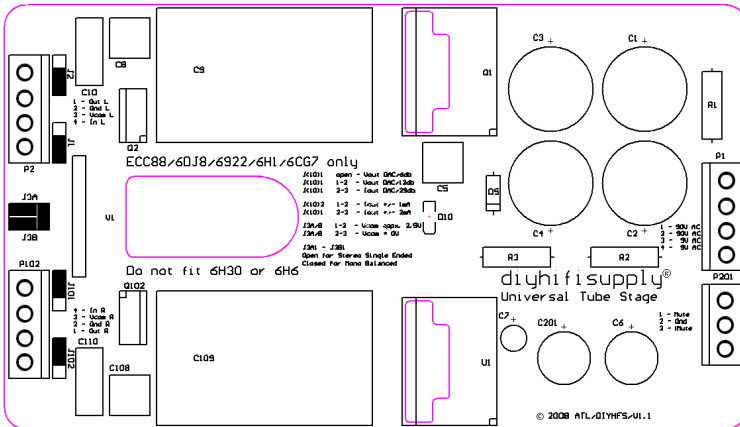

The input connections should follow the Scheme shown underneath:

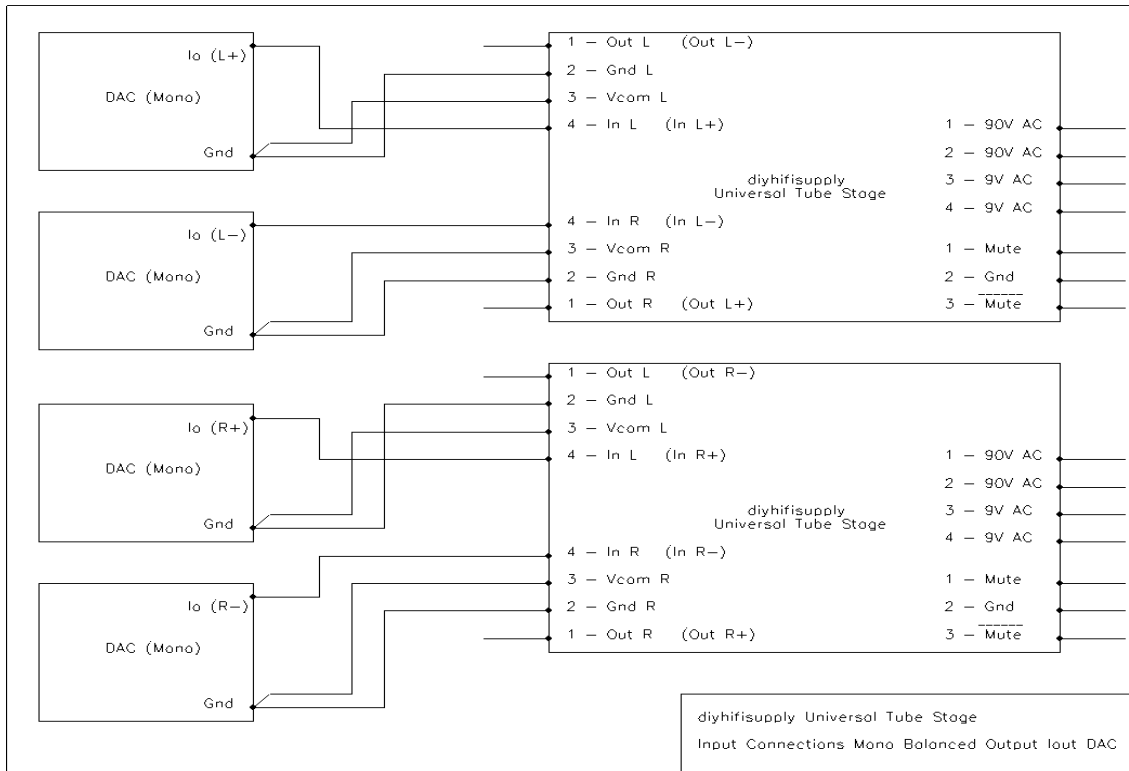

All Ground connections and the Vcom connections must be made to the respective channels DAC's Analogue Ground Pins.

### 3.07 – Settings and Input wiring for current output DAC, stereo, single ended, 1mA full scale current, ~2.5V reference voltage

Known examples of a DAC's requiring these settings is are Philips TDA1543A and TDA1545A (with modification as per Datasheet Note 5) and Burr Brown PCM67 & PCM69.

This type of DAC requires the following jumper settings:

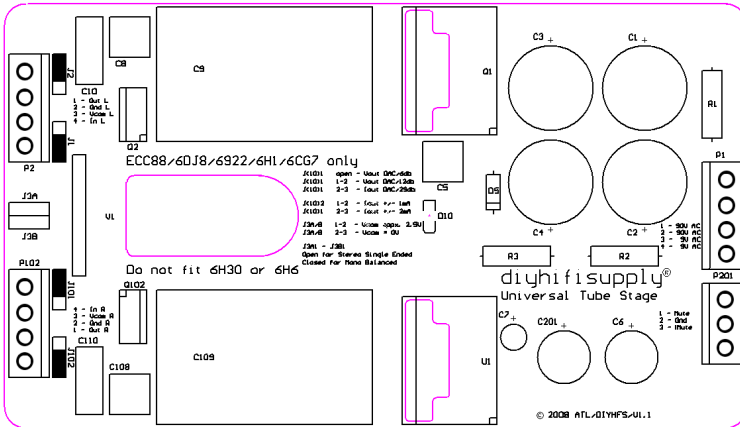

The input connections should follow the Scheme shown underneath:

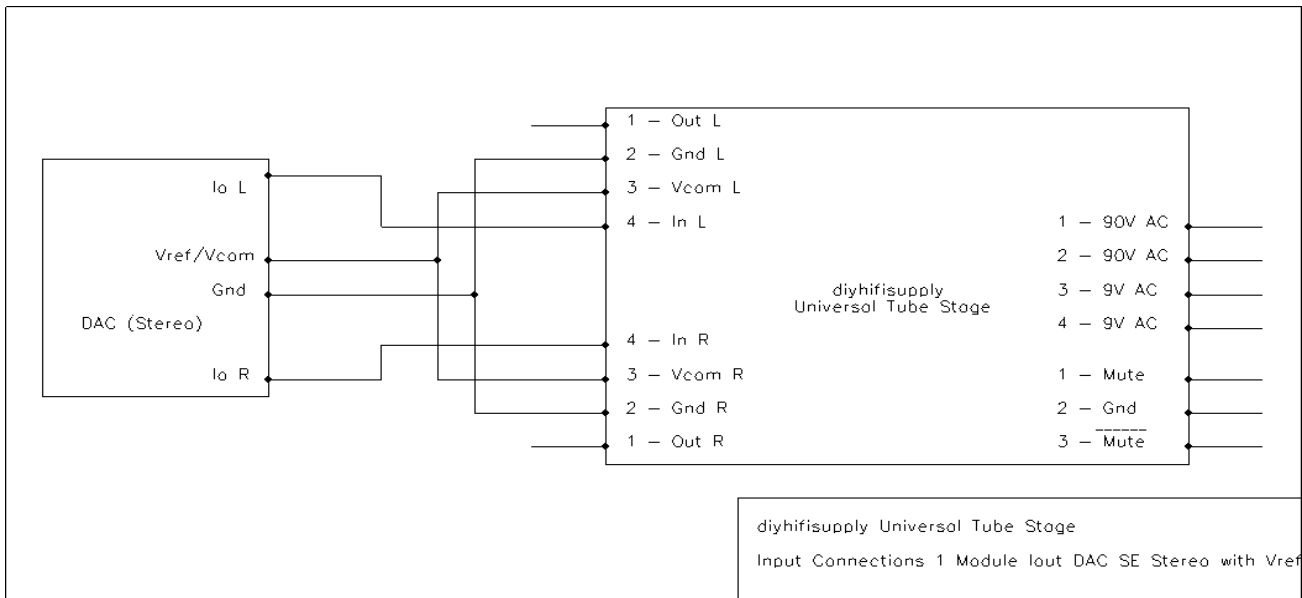

All Ground connections must be made to the DAC's Analogue Ground Pin. All Vcom connections from the Universal Tube Output Stage must be made to the "Reference Voltage (Vref)" or "Common Mode Voltage (Vcom)" Pin(s) on the DAC.

### 3.08 – Settings and Input wiring for current output DAC, balanced Stereo DAC's, balanced output, 1mA full scale current, 2.5V reference voltage

Known examples of DAC's requiring these settings are Burr Brown PCM1738 as well as Analog Devices AD1853. These types of DAC require the following jumper settings:

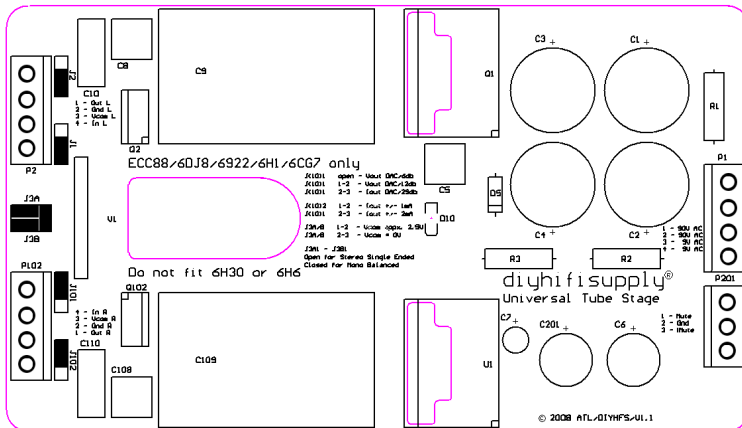

The input connections should follow the Scheme shown underneath:

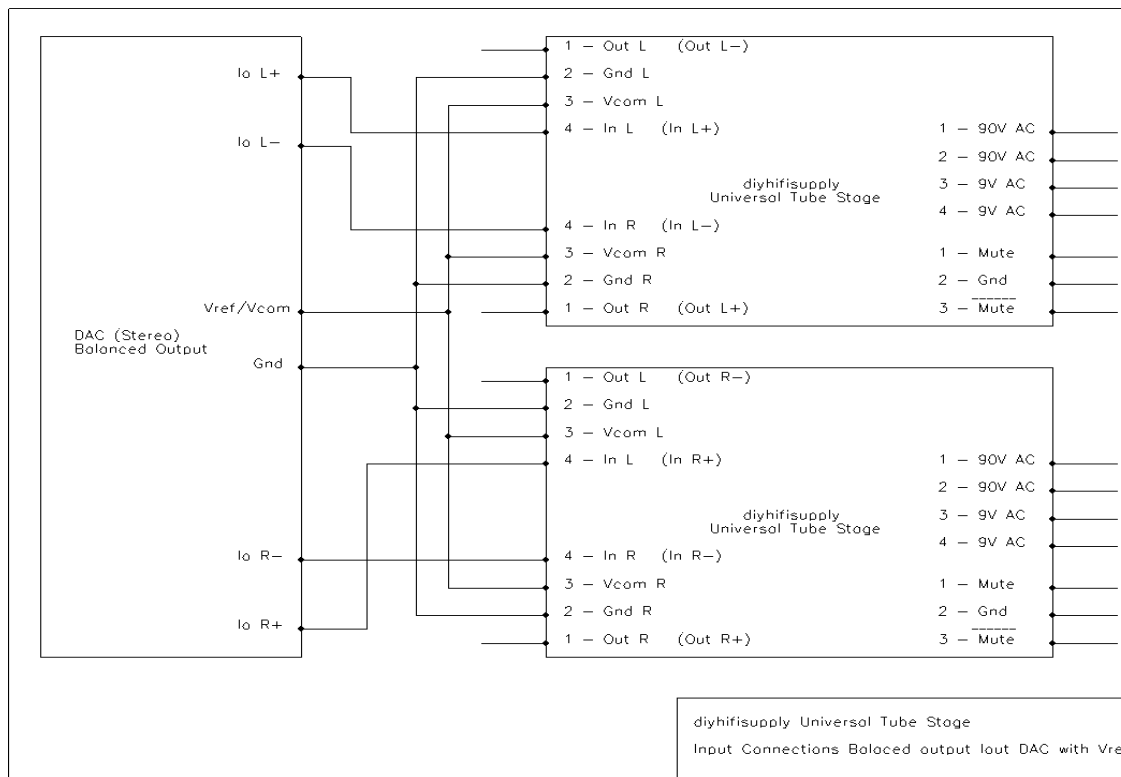

All Ground connections must be made to the DAC's Analogue Ground Pin. All Vcom connections from the Universal Tube Output Stage must be made to the "Reference Voltage (Vref)" or "Common Mode Voltage (Vcom)" Pin(s) on the DAC.

### 3.09 – Settings and Input wiring for current output DAC, balanced Stereo DAC's, balanced output, 4mA full scale current, 2.5V reference voltage

A known example of a DAC requiring these settings is the Analog Devices AD1955. This type of DAC requires the following jumper settings:

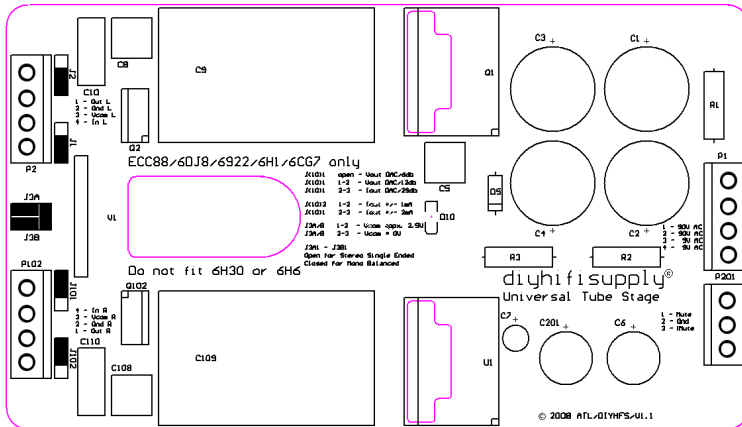

The input connections should follow the Scheme shown underneath:

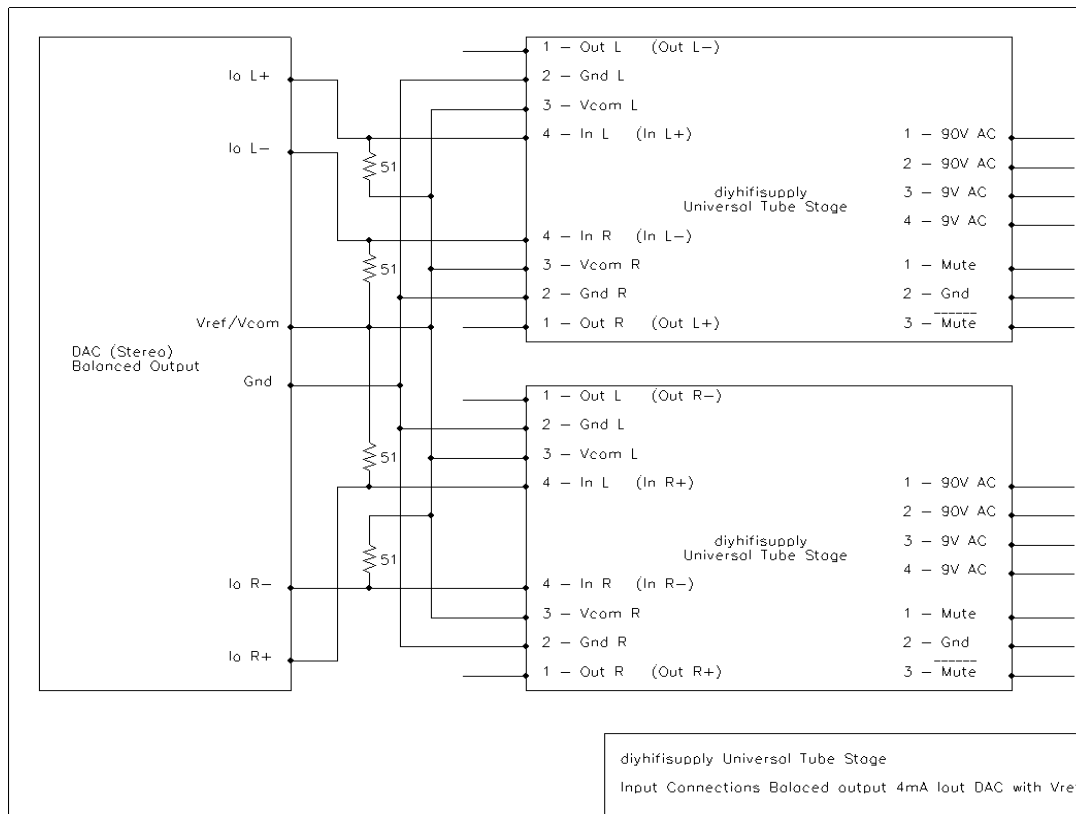

All Ground connections must be made to the DAC's Analogue Ground Pin. All Vcom connections from the Universal Tube Output Stage must be made to the "Reference Voltage (Vref)" or "Common Mode Voltage (Vcom)" Pin(s) on the DAC. An additional 51 Ohm Resistor needs to be wired in each channel between "In" and "Vcom".

### 3.10 – Settings and Input wiring for current output DAC, balanced Stereo DAC's, balanced output, 4mA full scale current, 0V reference voltage

Known examples of DAC's requiring these settings are Burr Brown PCM1792, PCM1794, PCM1796, PCM1798, DSD1792, DSD1794 and DSD1796. These types of DAC require the following jumper settings:

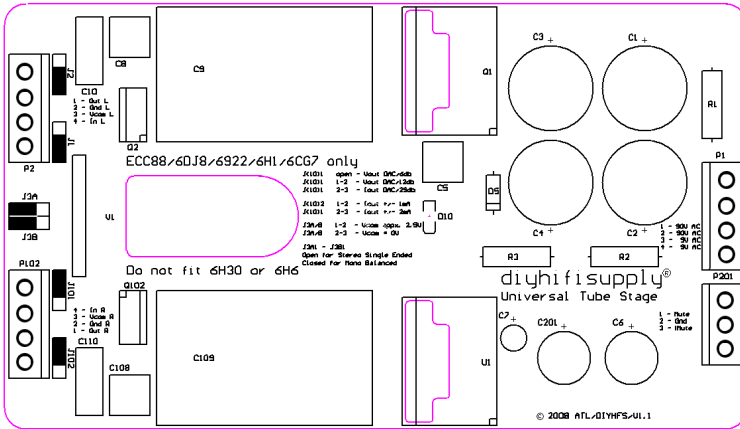

The input connections should follow the Scheme shown underneath:

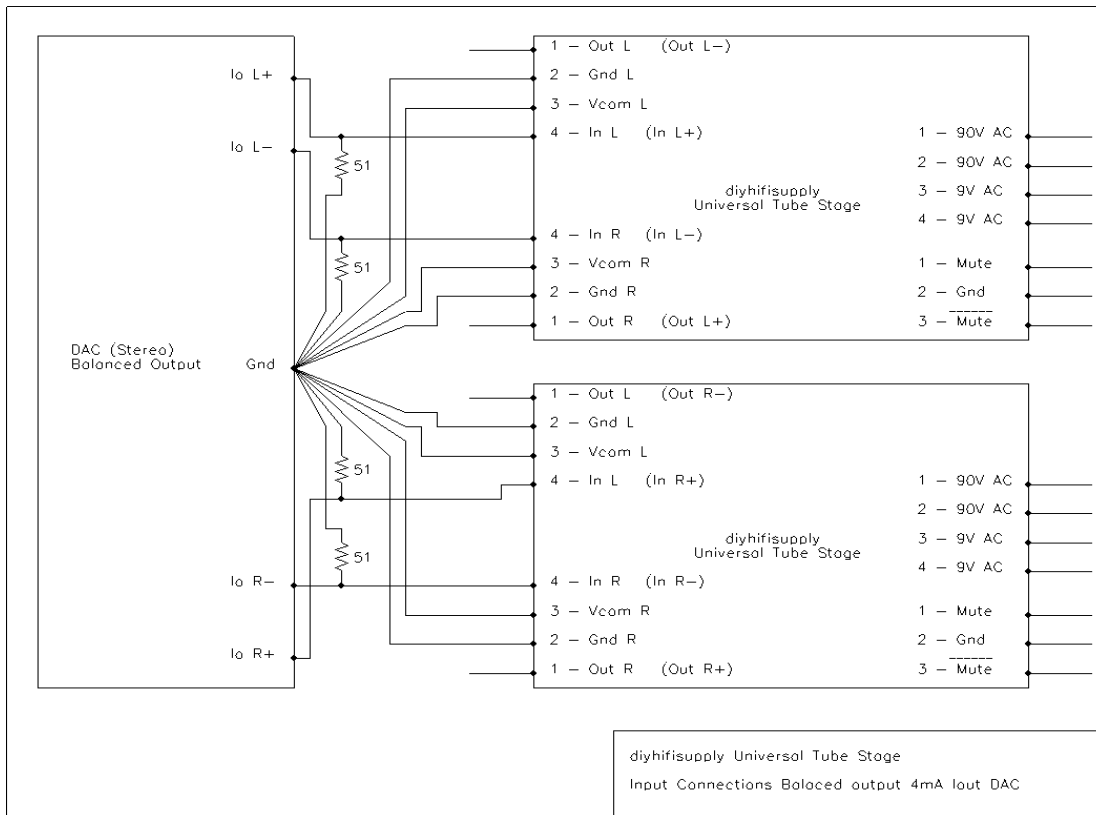

All Ground connections and the Vcom connections must be made to the respective channels DAC's Analogue Ground Pins.

### 3.11 – Settings and Input wiring for voltage output DAC, stereo, single ended, 1...1.5 VRMS full scale output voltage, 0V reference voltage

A known example of a DAC requiring these settings is the Crystal/Cirrus Logic CS4328.

This type of DAC requires the following jumper settings:

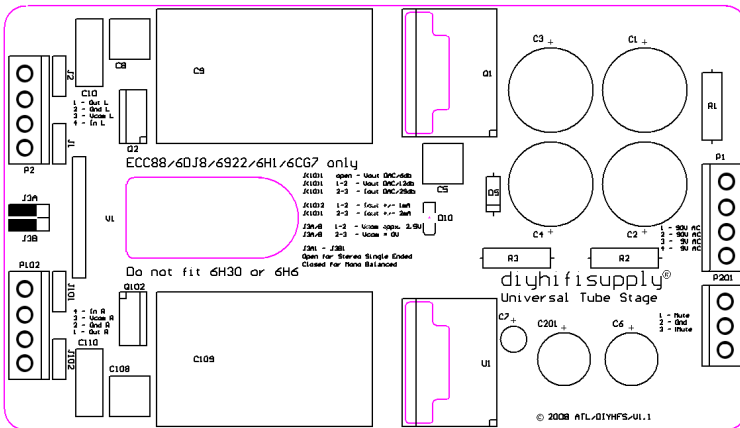

The input connections should follow the Scheme shown underneath:

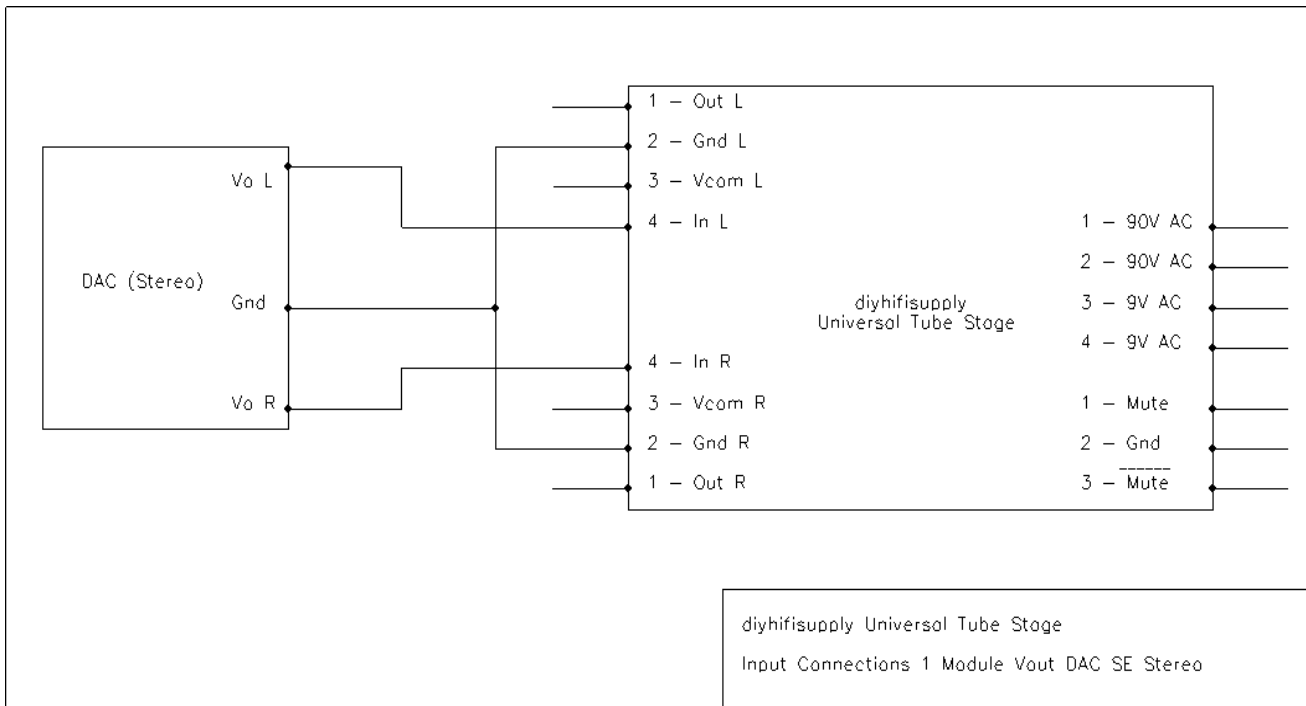

All Ground connections must be made to the DAC's Analogue Ground Pin.

### 3.12 – Settings and Input wiring for voltage output DAC, stereo, single ended, 1...1.5 VRMS full scale output voltage, 2.5V reference voltage

Known examples of DAC's requiring these settings are

Analog Devices AD1866, AD1868, AD1857 / 58 / 59, AD1958

Asahi Kasei (AKM) AK4384, AK4385, AK4386, AK4387, AK4388, AK4344, AK4345, AK4364

Burr Brown PCM1716, PCM1723, PCM1727, PCM1728, PCM1732, PCM1740, PCM1741, PCM1742, PCM1744, PCM1748, PCM1753 / 54 / 55, PCM1770 / 71 / 72 / 73 / 74, PCM1780 / 81 / 82, PCM2704 / 05 / 06 / 07, DSD1702

Crystal/Cirrus Logic CS4327, CS4334 / 35 / 36 / 37 / 38 / 39 / 40 / 41 / 44 / 45 / 46 / 48 / 49 /

Nippon Precision Circuits (NPC) SM5882, SM5883, SM5885

Pioneer PE8001

Philips TDA1305T, TDA1306T / 86T, TDA1311T / 12T / 13T, TDA1549, UDA1320 / 21 / 22 / 24

Sanyo LC78835

Panasonic MN662710 (Technics „Mash“ CD-Player on one chip IC)

Wolfson Micro WM8716

This type of DAC requires the following jumper settings:

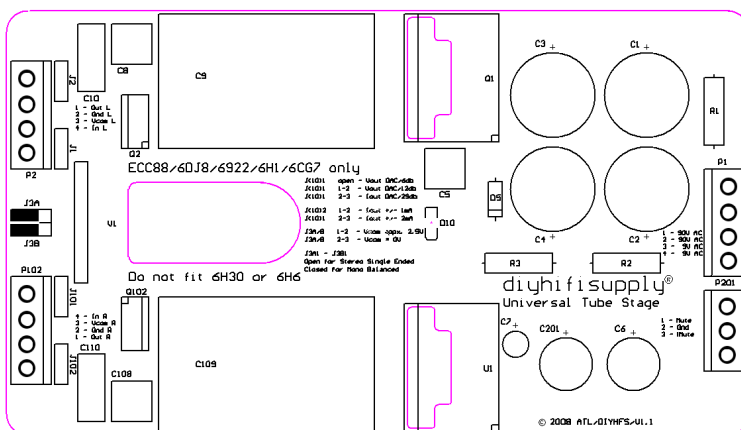

The input connections should follow the Scheme shown underneath:

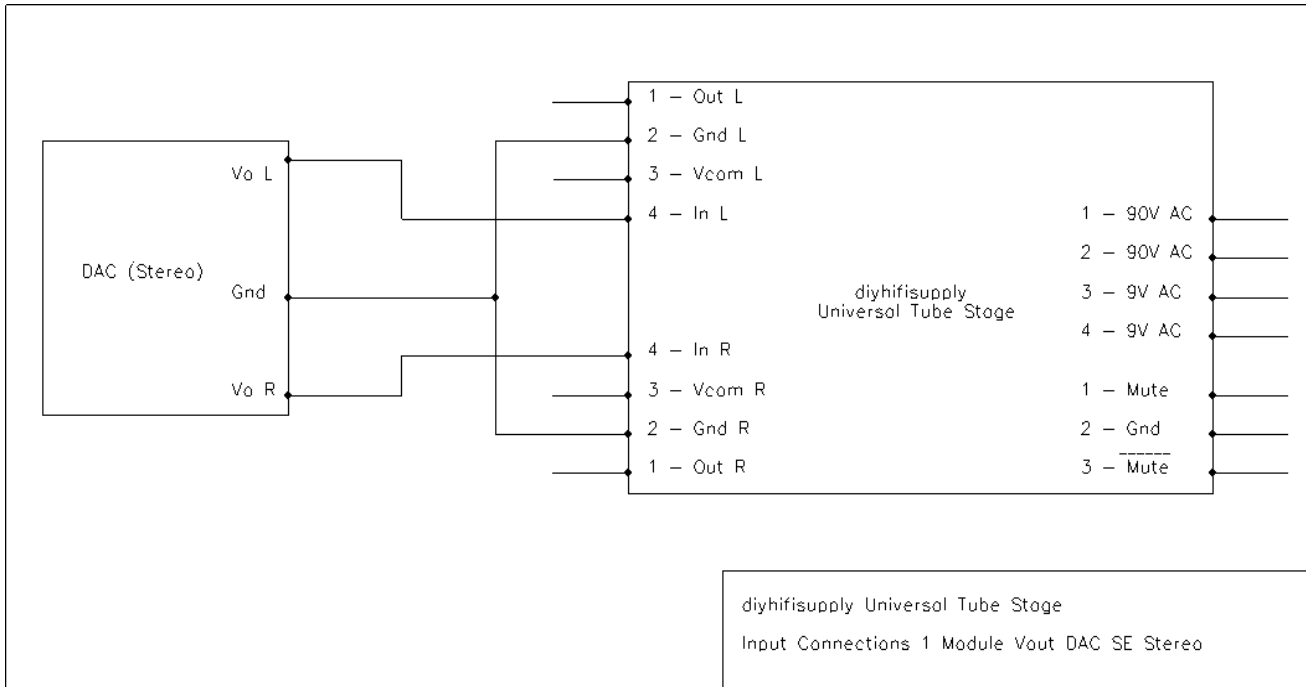

All Ground connections must be made to the DAC's Analogue Ground Pin.

### 3.13 – Settings and Input wiring for voltage output DAC, stereo, balanced output, 2...3 VRMS full scale output voltage, 2.5V reference voltage

Known examples of DAC's requiring these settings are

Analog Devices AD1852, AD1854

Asahi Kasei (AKM) AK4324, AK4382, AK4394, AK4395, AK4396, AK4397

Burr Brown PCM1791, PCM1793, DSD1791, DSD1792

Crystal/Cirrus Logic CS4329, CS4350, CS4390, CS4391, CS4392, CS4396, CS4397, CS4398, CS43122

Nippon Precision Circuits (NPC) SM5865, SM5866, SM5872 (Note SM5865/66 Datasheets misidentify the outputs as current types)

Niigata Seimitsu FN1242A (Luxman "Fluency" DAC)

Philips TDA1547, SAA7350

Pioneer PD2026, PD2028, PD2029

Sony CXD2552Q

Wolfson Micro WM8740, WM8741

This type of DAC requires the following jumper settings:

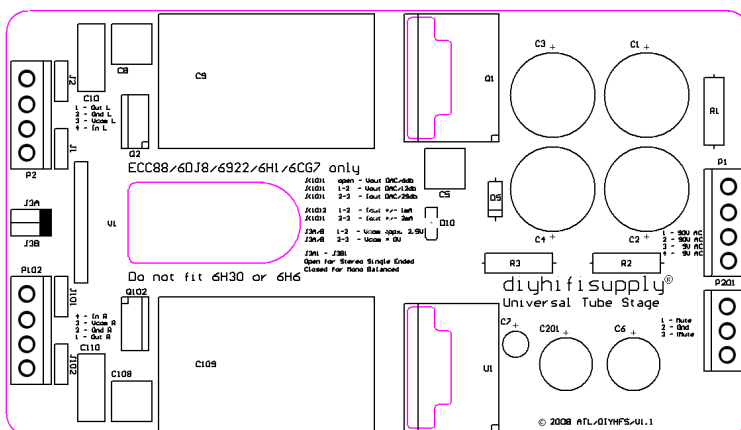

The input connections should follow the Scheme shown underneath:

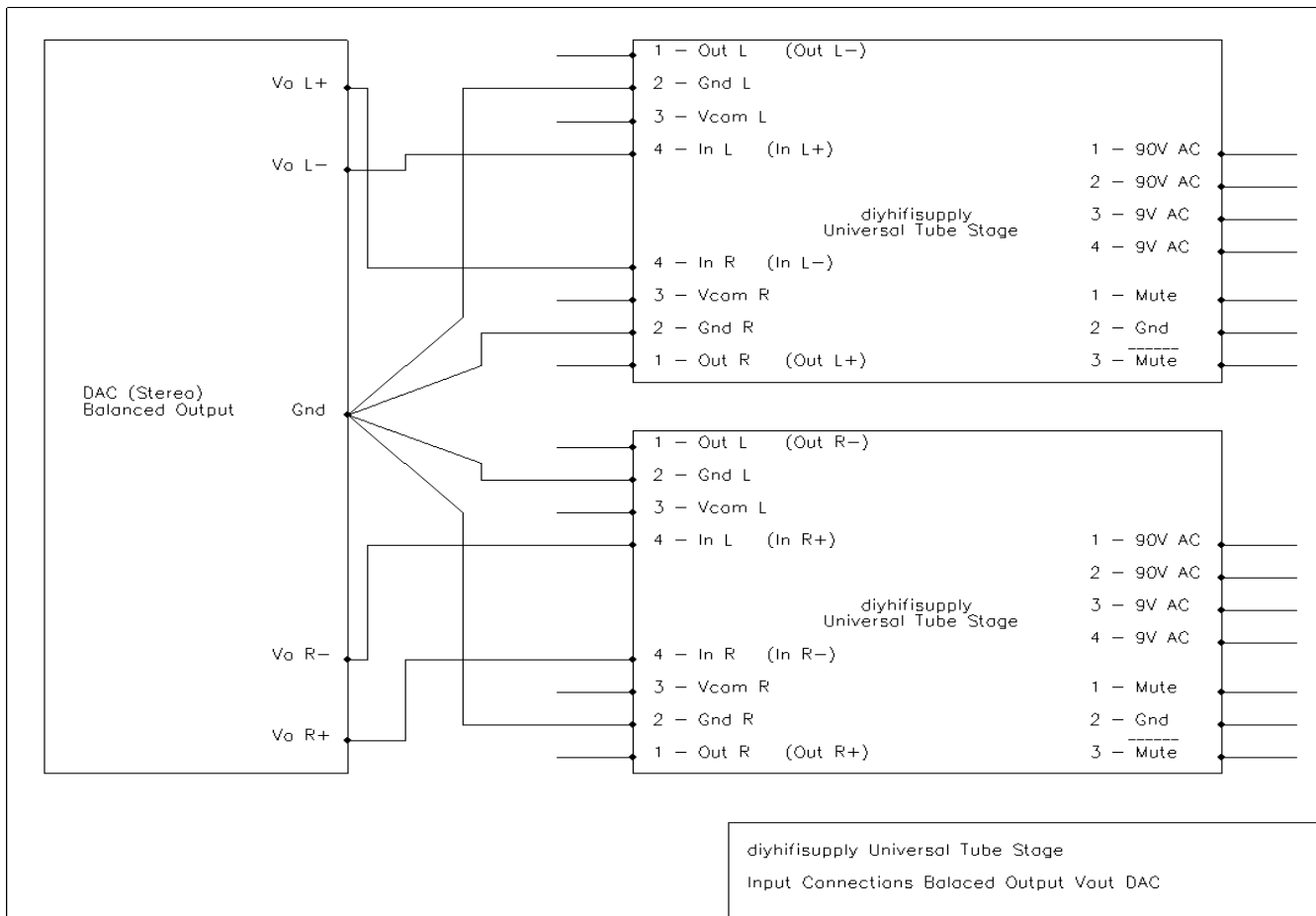

All Ground connections must be made to the DAC's Analogue Ground Pin.

### 3.14 – Settings and Input wiring for single ended stereo output from voltage output DAC, stereo, balanced output, 2..3 VRMS full scale output voltage, 2.5V reference voltage

Known examples of DAC's requiring these settings are listed under 3.13.

This type of DAC requires the following jumper settings:

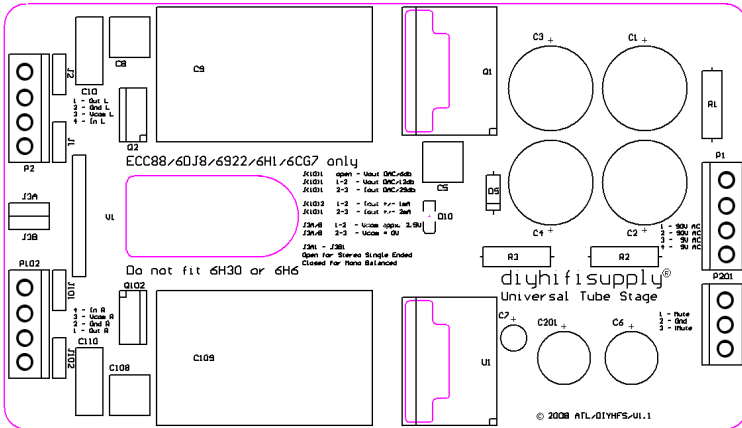

The input connections should follow the Scheme shown underneath:

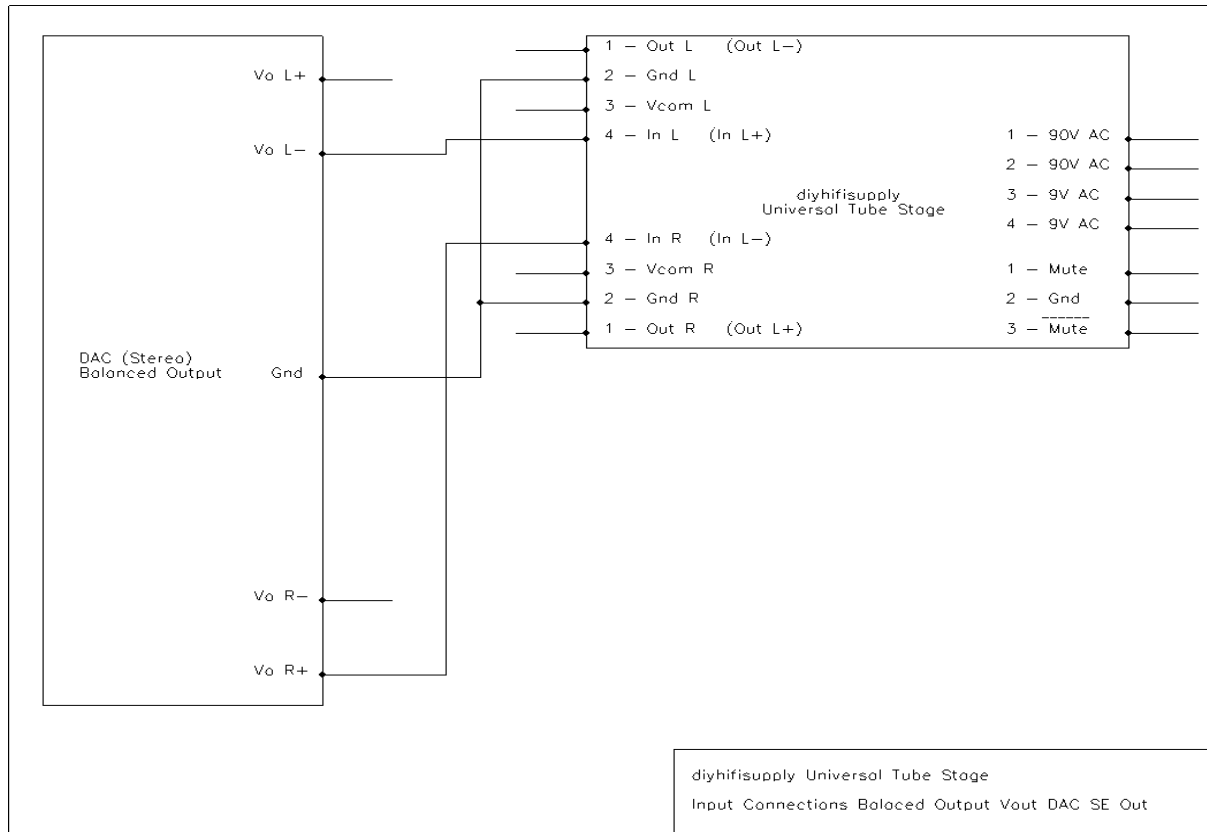

All Ground connections must be made to the DAC's Analogue Ground Pin.

#### **4 – Other applications of the Universal Tube Output Stage**

Due to its design the Universal Tube Output Stage can be used in a number of additional Roles.

Each module can be configured as Single Ended or Balanced Circuit with the following levels of Gain and input Impedances (assuming source with output impedances that are small compared to the input impedance):

Gain	Input Impedance
~ 30dB	~ 47 kOhm
~ 12dB	~ 200 kOhm
~ 6dB	~ 400 kOhm

In addition other gain levels can be set by using the “30dB Gain” configuration and inserting a resistor in series with the signal. Some of them, in steps of 6db are listed below

Gain	Series Resistor
~ 30dB	1 kOhm
~ 24dB	33 kOhm
~ 18dB	91 kOhm
~ 12dB	220 kOhm
~ 6dB	430 kOhm

Due to the extremely wide number of possibilities in configuring these Modules we are showing only a small number of the most common options.

### 4.1 – Settings and Input wiring for use as SE Linestage 6db Gain

This type of Application requires the following jumper settings:

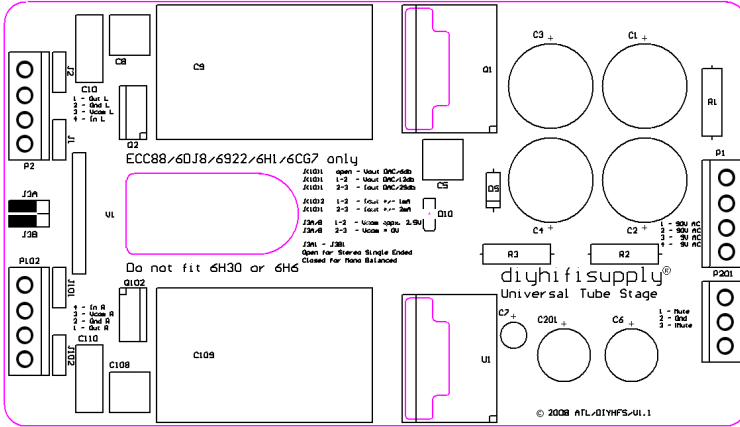

The input connections should follow the Scheme shown underneath:

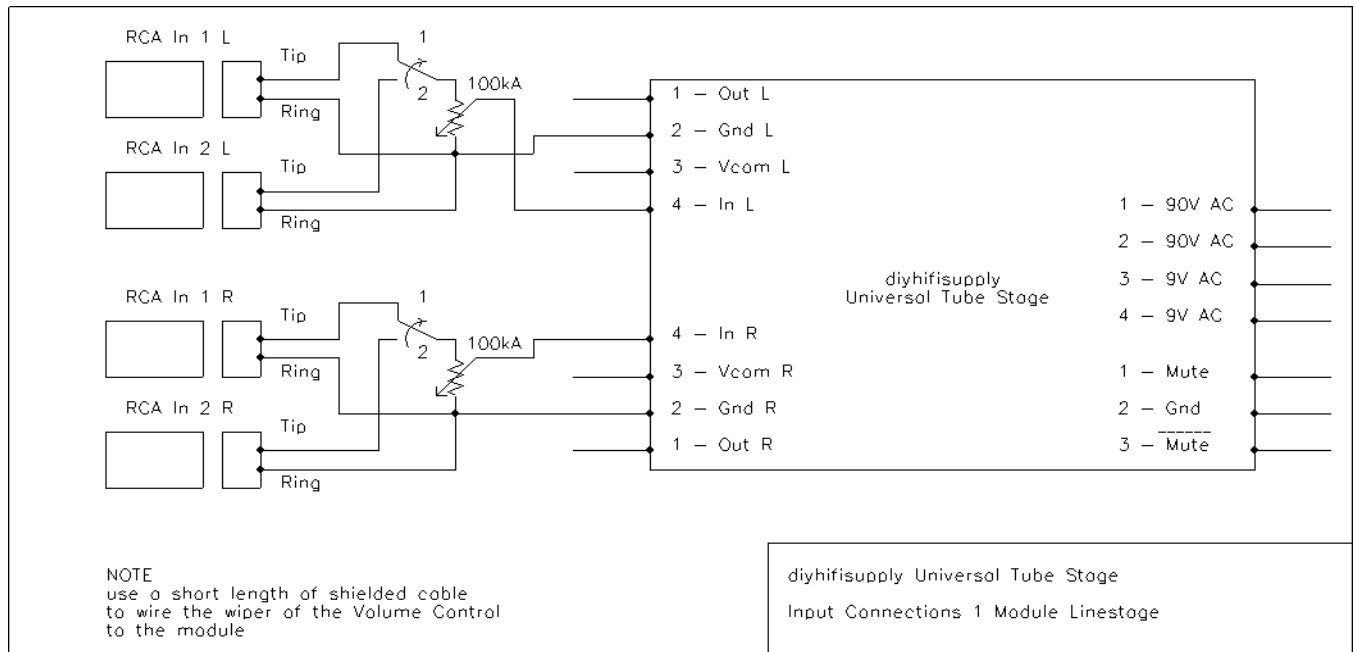

## 4.2 – Settings and Input wiring for use as SE Linestage 12db Gain

This type of Application requires the following jumper settings:

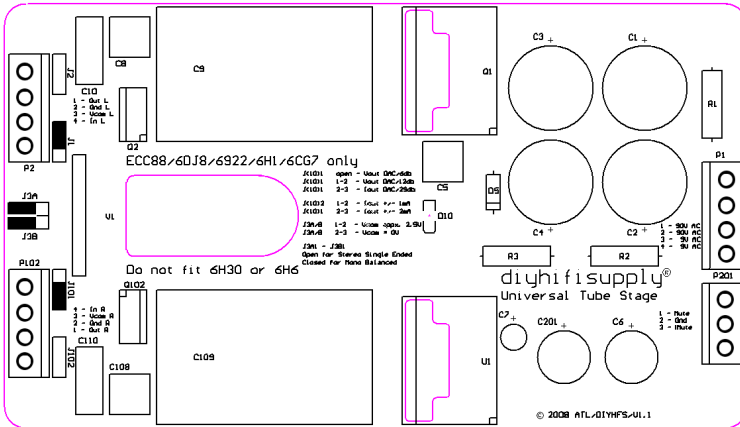

The input connections should follow the Scheme shown underneath:

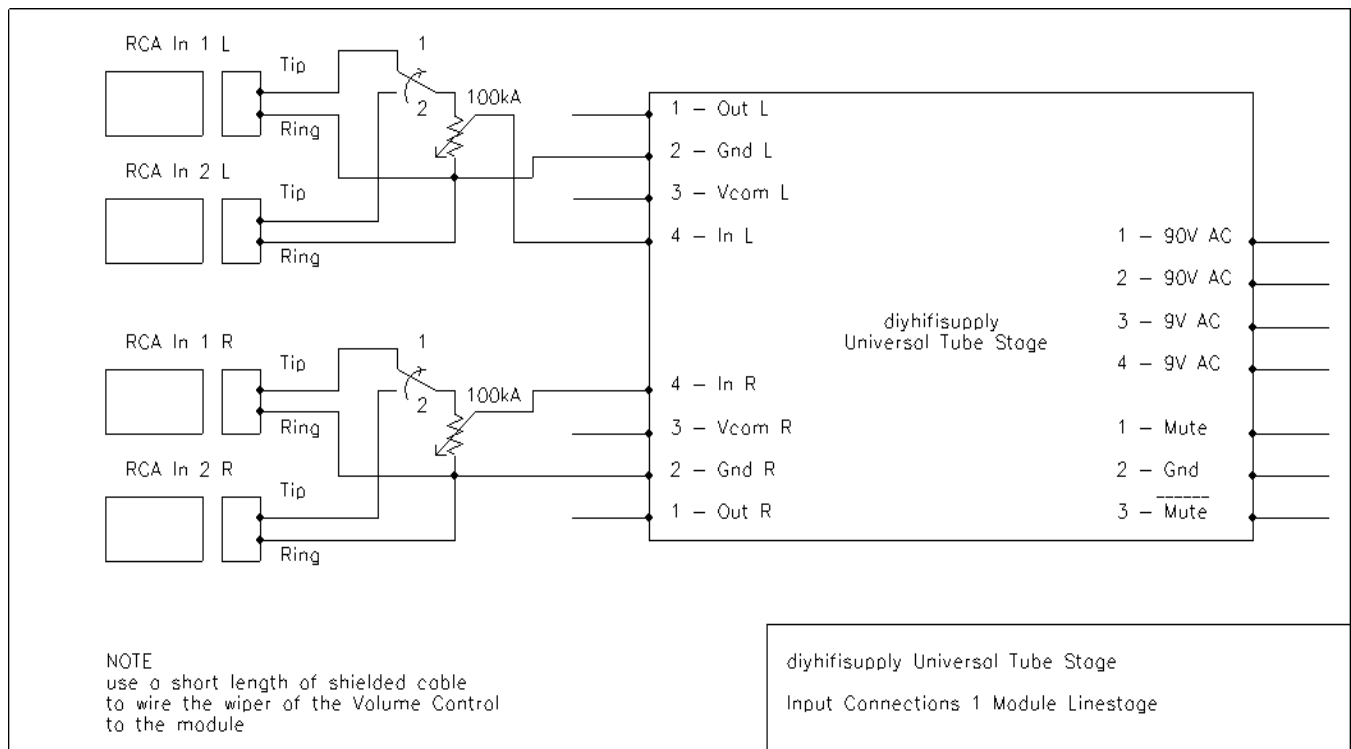

### 4.3 – Settings and Input wiring for use as Balanced Linestage 6db Gain

This type of Application requires the following jumper settings:

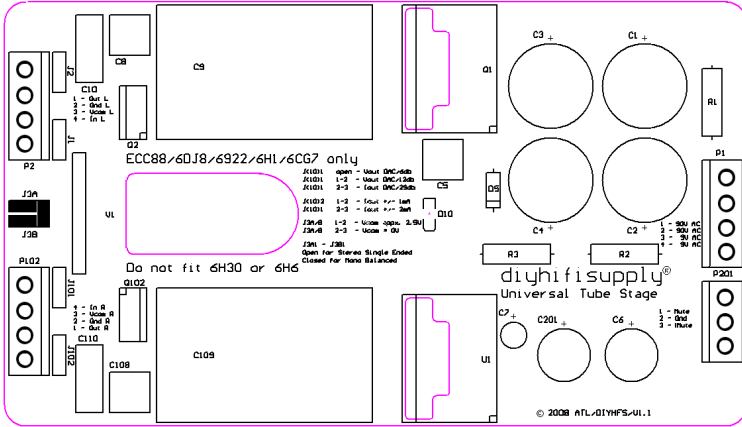

The input connections should follow the Scheme shown underneath:

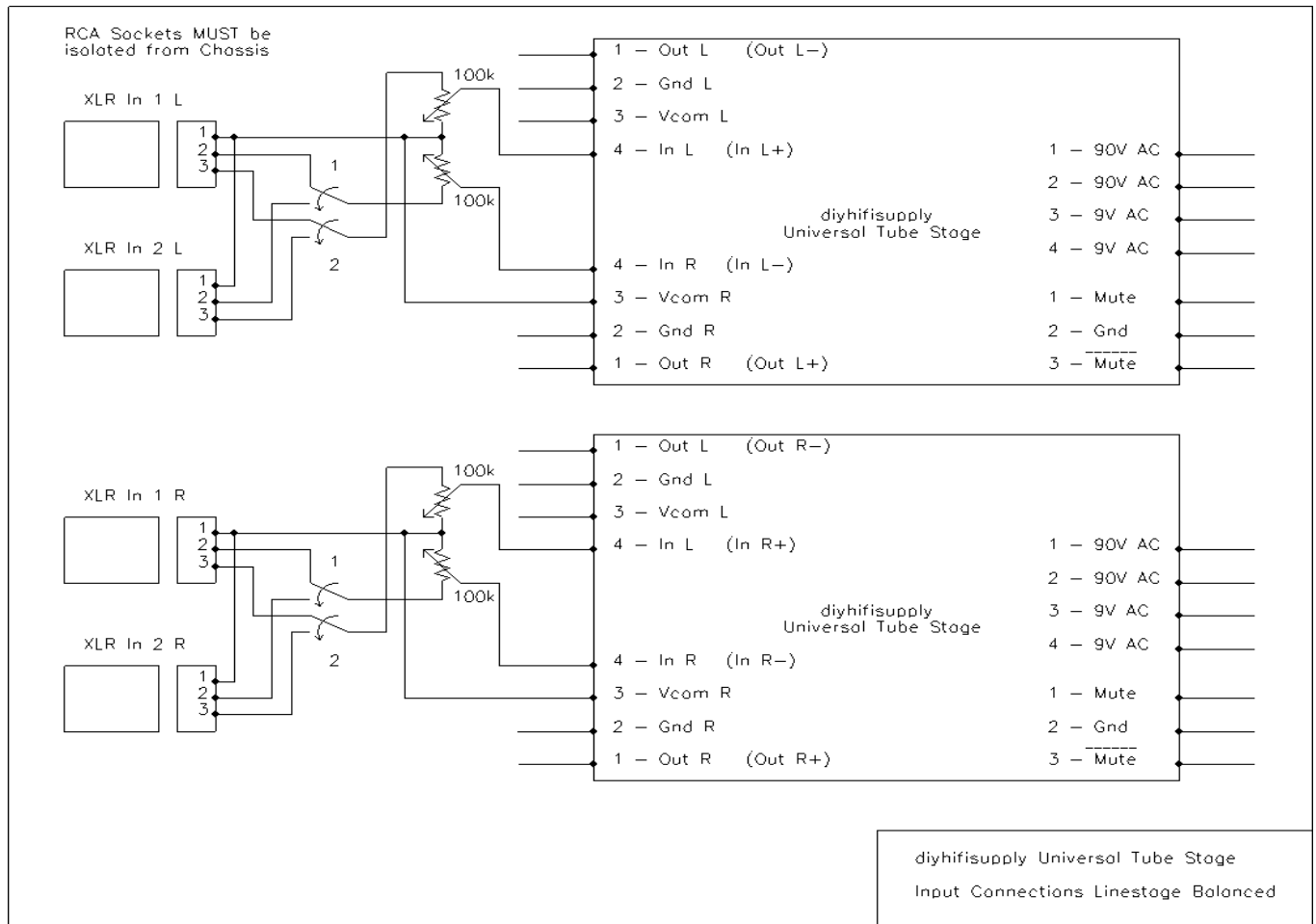

### 4.4 – Settings and Input wiring for use as Balanced Linestage 12db Gain

This type of Application requires the following jumper settings:

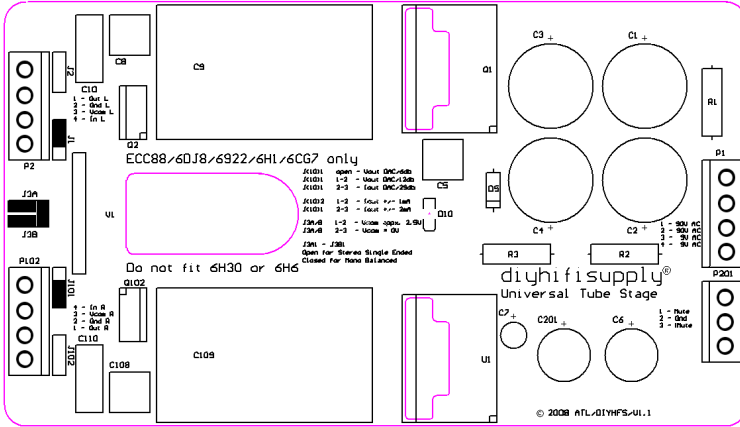

The input connections should follow the Scheme shown underneath:

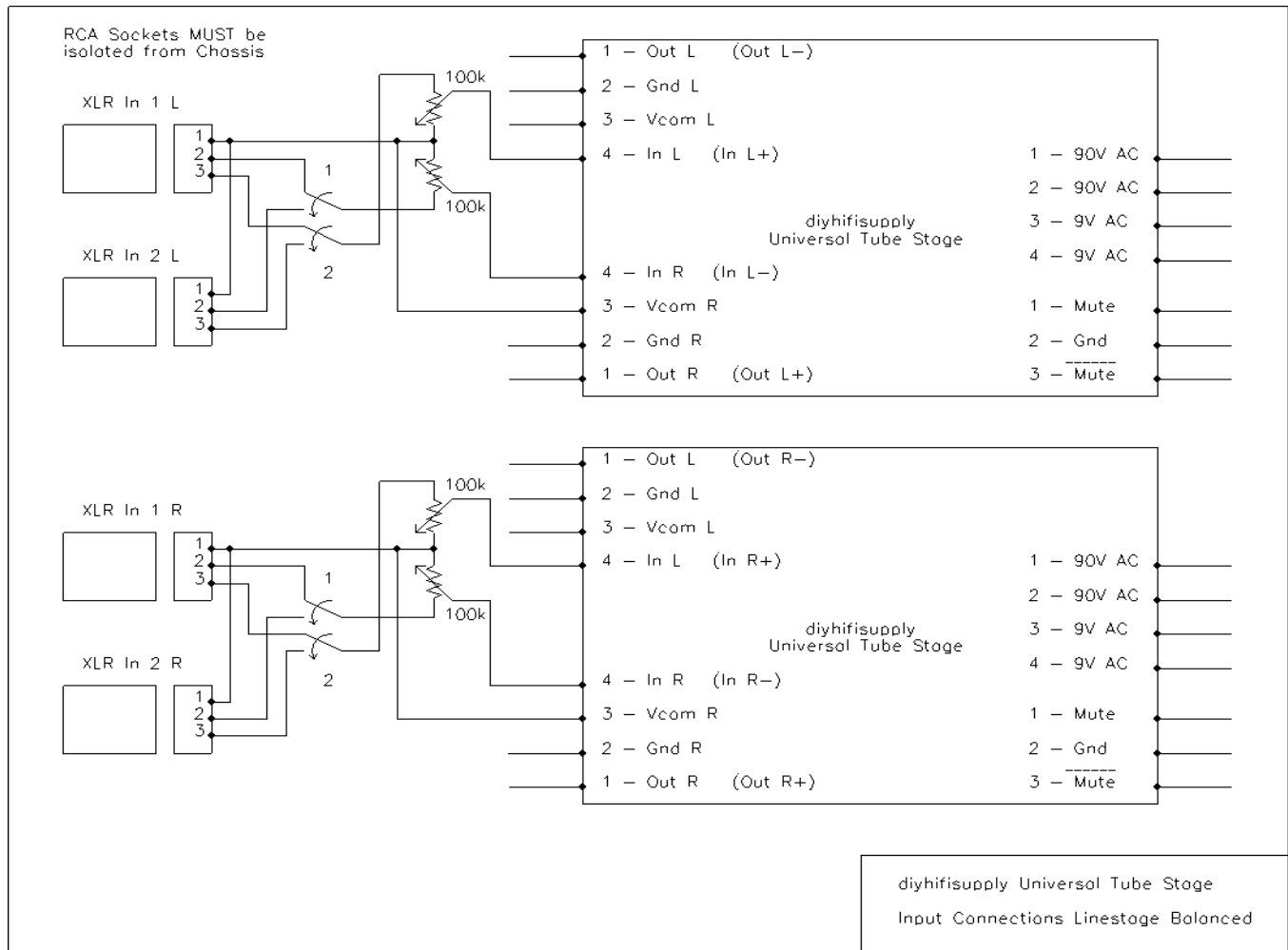

## 4.5 – Settings and Input wiring for use as simple single ended stereo RIAA equalisation preamplifier

One possible application is to use two Universal Tube Output Stages together with a minimal number of external components to form the RIAA Equalisation network as Phonostage.

One Module will be used for each channel, so Tubes used should be identical in manufacturing and preferably matched.

This application will produce a Moving magnet and High Output Moving compatible Phonostage with 47kOhm input impedance, 36 – 38db Gain (depends on the exact tube type and manufacturer used).

When using narrow tolerance or selected parts (tolerance 0.5% or better for capacitors and 0.1% for resistors) for the RIAA as equalisation the RIAA EQ will be better than +/-0.1dB from 100Hz to 20KHz with an 0.5dB rolloff at 20Hz and a -3db point below 10Hz.

If 1% tolerance resistors and 5% tolerance capacitors are used the RIAA EQ will be better than +/- 0.2dB with no more than 0.6db rolloff at 20Hz.

This type of Application requires the following jumper settings:

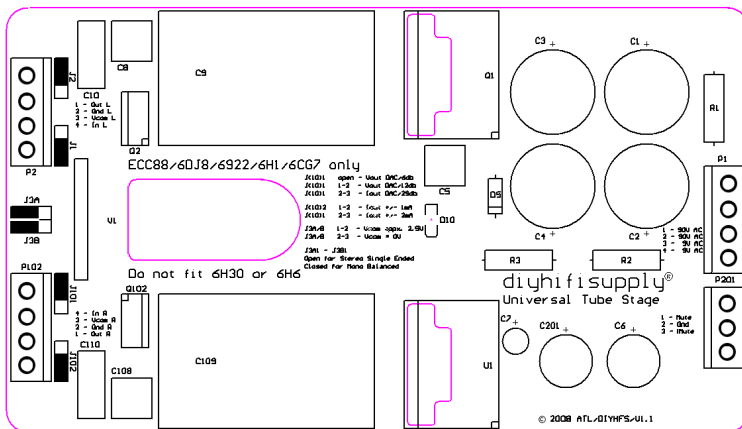

The input connections and other connections should follow the Scheme shown underneath.

The Resistors and Capacitors form the RIAA Equalisation. In principle other applications (such as tape head amplifier) could use the same principle diagram but with the Equalisation Network values adjusted to suit.

