

Universal Film Capacitor Power Supply Installation Manual

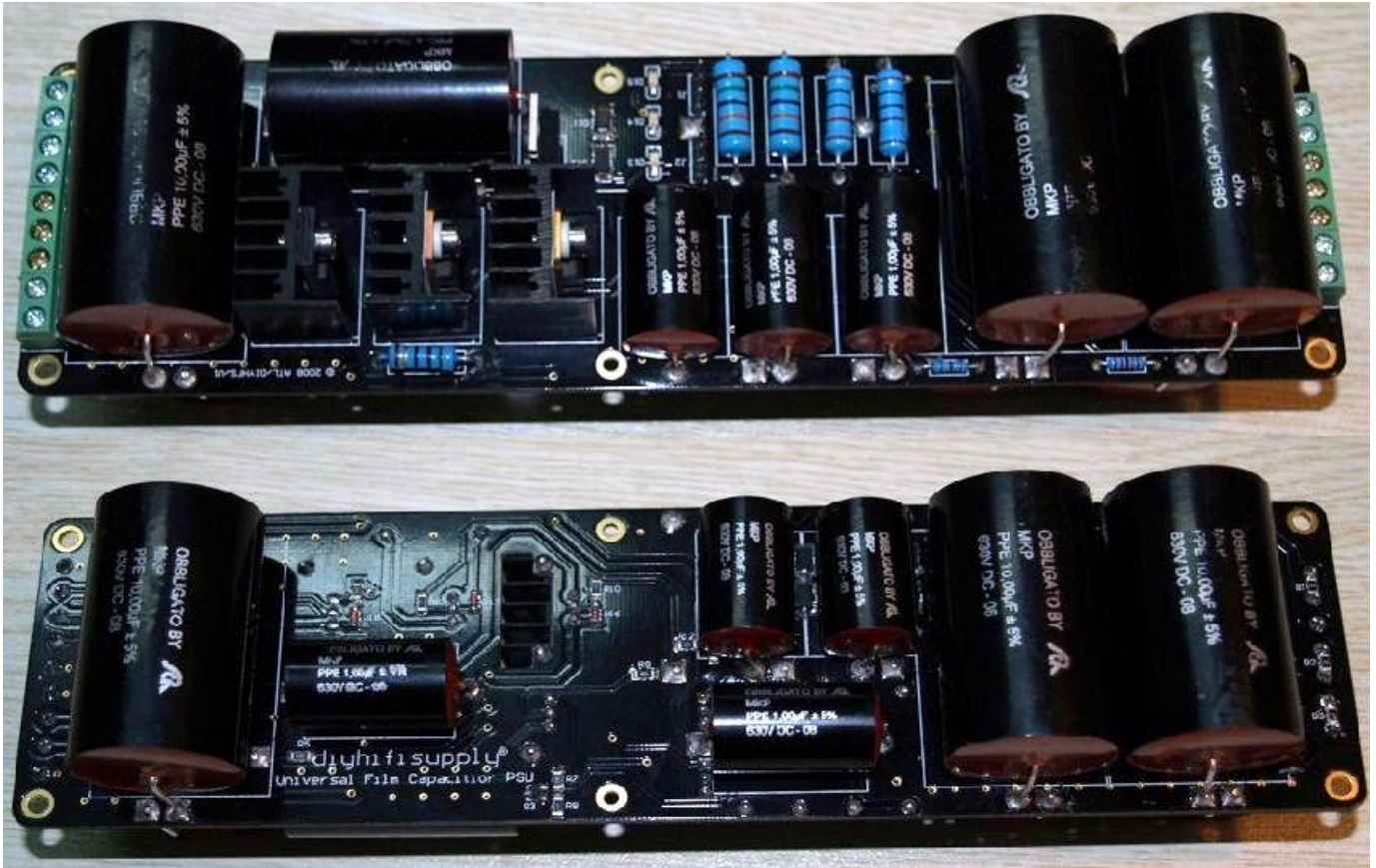

Universal Film Capacitor Power Supply Installation Manual

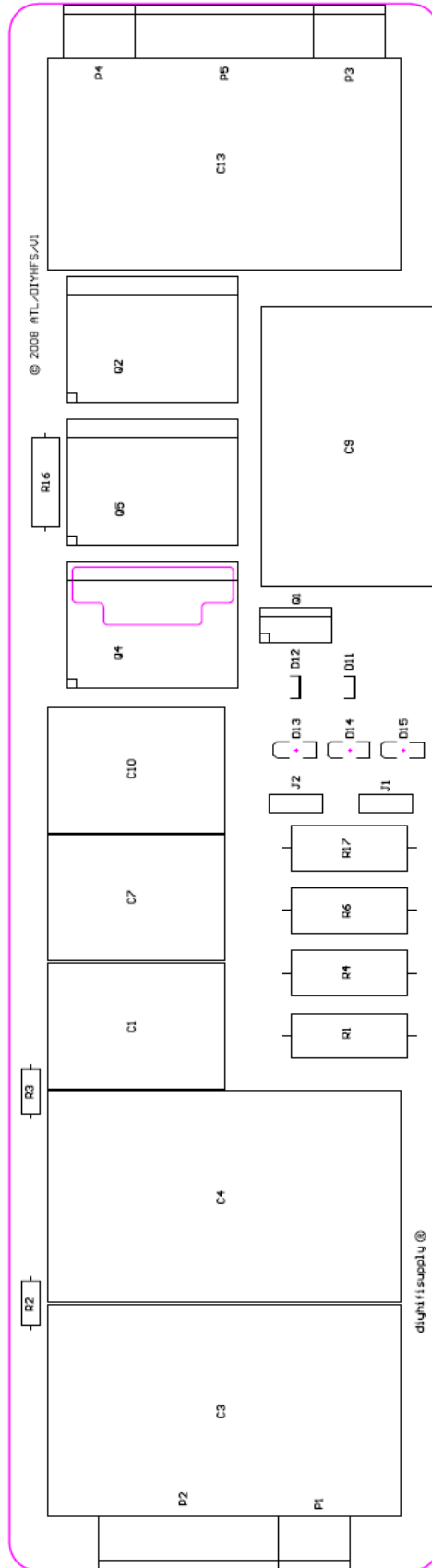

Universal Film Capacitor Power Supply Installation Manual *Introduction and Overview*

The diyhifisupply® Universal Film Capacitor Power Supply has been designed to offer a State of the Art power supply for tube amplifiers and tube preamplifiers. Due to its compact size it can be used both for retro-fit upgrades in many tube amplifiers and preamplifiers as well as for new designs.

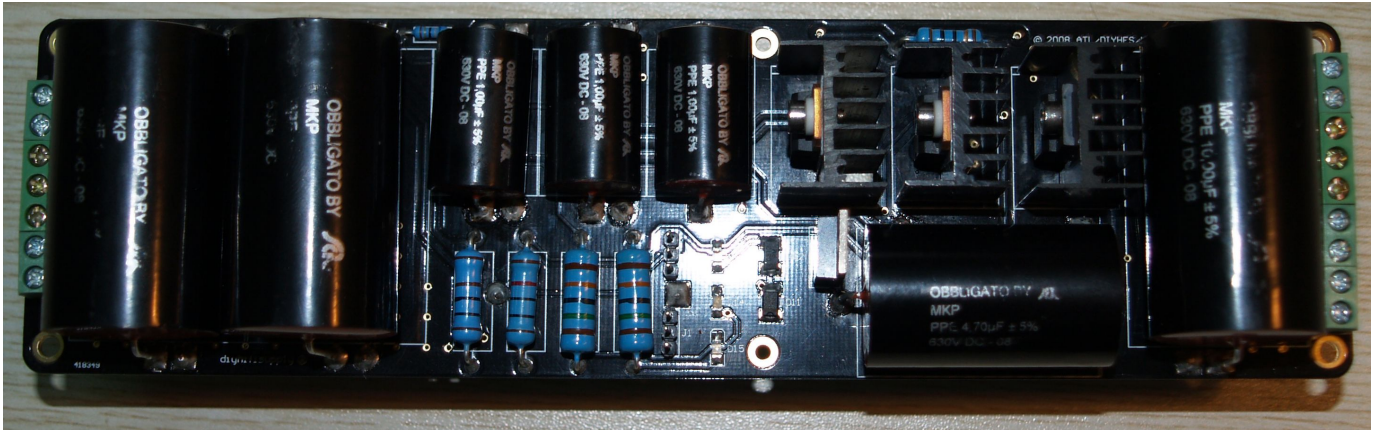

The Universal Film Capacitor Power Supply has on board a “schottky-enhanced” solid state rectifier bridge (or half bridge for use with centre tapped secondary transformers).

Additionally any form of external tube rectifier can be used. Of course heater windings for tube rectifier must be present on mains transformer. Traditional dual anode tube rectifiers such as 5U4 can be used even if the mains transformer used lacks a centre tap for the high voltage winding.

The Universal Film Capacitor Power Supply is for use with input voltages of no greater than 380V AC for Solid State rectifiers and 420V AC for Tube rectifiers.

On the output side the Universal Film Capacitor Power Supply provides +B (High tension/Anode Supply) and Ground, -C (Negative Bias/Helper voltage) and Ground. Additionally a line for connecting to the ABS over current sense circuit forms, if used, a protection against of the amplifier against faulty output valves.

The Universal Film Capacitor Power Supply tracks the transformer secondary voltage just like a Choke Filtered/Choke Input Supply. The “electronic choke” circuit basically tracks the lowest point in the rectified and first capacitor stage filtered supply and drops another around 6V to allow it to operate under all conditions. Thus any losses are set to the minimum required for the circuit to function.

For illustration, consider a 300B amplifier channel at 80mA current for the 300B plus 20mA for driver stage, giving 100mA current drawn. Let us use a common set of components and use a 5U4 rectifier with a single 360V/0.2A winding.

Universal Film Capacitor Power Supply Installation Manual

On the output the PSU in “virtual battery” mode (J2* selects Virtual battery/Choke, 1-2 Virtual Battery / 2-3 Virtual Choke) behaves basically like a very large choke with a very large value capacitor (think something 500H/2200uF) followed by 10R/20uF, so above 800Hz the 20uF capacitor dominates the output impedance and sound quality. So adding capacitors on the output is not necessary. One may still add capacitance to the output; such capacitors are best wired in locally, directly at the circuit being supplies. The Virtual Battery Mode is "default" and requires no external capacitors. It in essence simulates a very low impedance power supply electronically.

It must be used if no external capacitors are present.

In “virtual choke” mode (J2* selects Virtual battery/Choke, 1-2 Virtual Battery / 2-3 Virtual Choke) the output impedance is very high (but still with only around 15 Ohm DC Resistance); the combination of on-board and external capacitor dominates the in circuit impedance completely. An additional large value capacitor should be added. This capacitor size must be based on the demands of the circuit being supplied normally one would size the external capacitor based on the final PSU Capacitor supplying the power stage in the original design or use suitable design equations.

The negative bias voltage can be set to around -80V or -140V maximum via a Jumper (J1 selects 80/140V Bias voltage, 1-2 -140V Bias / 2-3 -80V Bias, note: J1* is set for -80 V bias from the factory). When loaded by either one ABS Module or a set of resistor chains with no less than 10k total resistance, -80V will be reached with an input voltage of at least 150V AC while -140V under the same conditions require at least 240V AC on the PSU Modules input.

In applications requiring more current than the 8mA or 14mA it may be necessary to determine the actual output voltage under nominal load empirically.

For ease of application all connections on the Universal Tube Output Stage are provided as screw terminals and all configurations are handled by gold-plated jumpers, so no soldering is required on the actual Universal Tube Output Stage Module.

For those desiring soldered connections instead we recommend to either unsolder the screw terminals and solder the wires in the holes thus available or to simply solder the wires to the solder pads below the PCB.

In the following Manual the application of the Universal Film Capacitor Power Supply is broken down into three distinct sections.

Section one covers the connections to the power supply transformer, while section two covers the output configurations. Section three presents some sample circuits illustrating a few possible uses of the Universal Film Capacitor Power Supply.

* The "1" Pin of J1/J2 is marked by a square solder pad, for both jumpers. It is the pin towards the heatsinks of the transistors.

Universal Film Capacitor Power Supply Installation Manual

1 – Input Connections

The Universal Film Capacitor Power Supply allows the use of transformers with a centre tapped secondary winding for the high tension supply as well as those offering a single, non centre tapped winding and external tube rectifiers can substitute the on board solid state ones.

Shown here is the connection for use with the on board rectification and a single, non centre tapped winding.

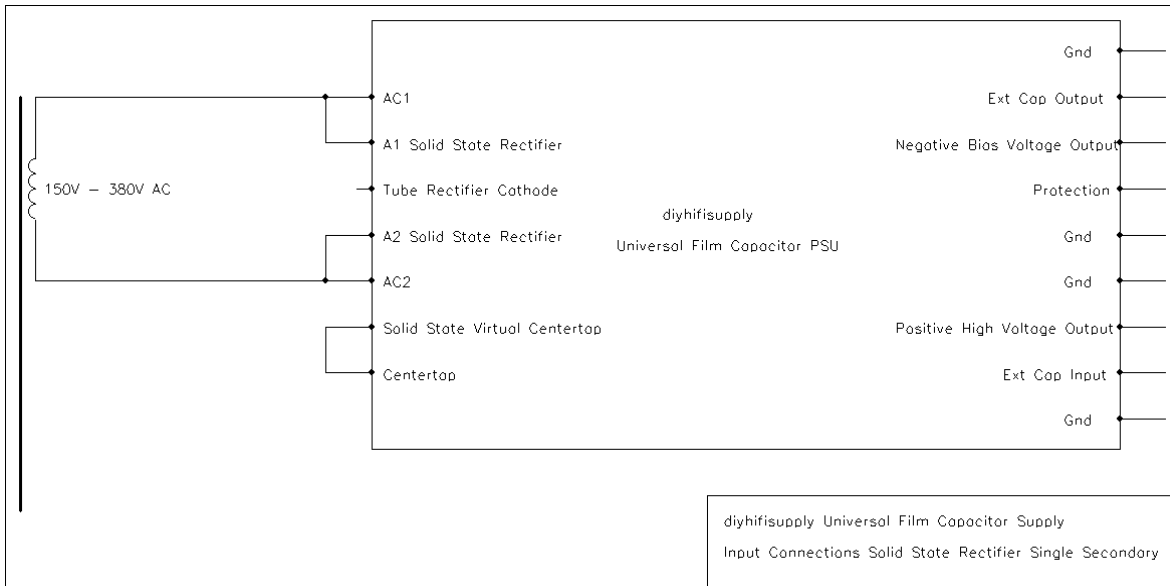

It is possible to wire a tube rectifier into the above circuit, the result is a output voltage that is lower, by around 10 – 20% but many critical listeners have expressed strong preferences for the use of tube rectifiers. In this case use the scheme shown below.

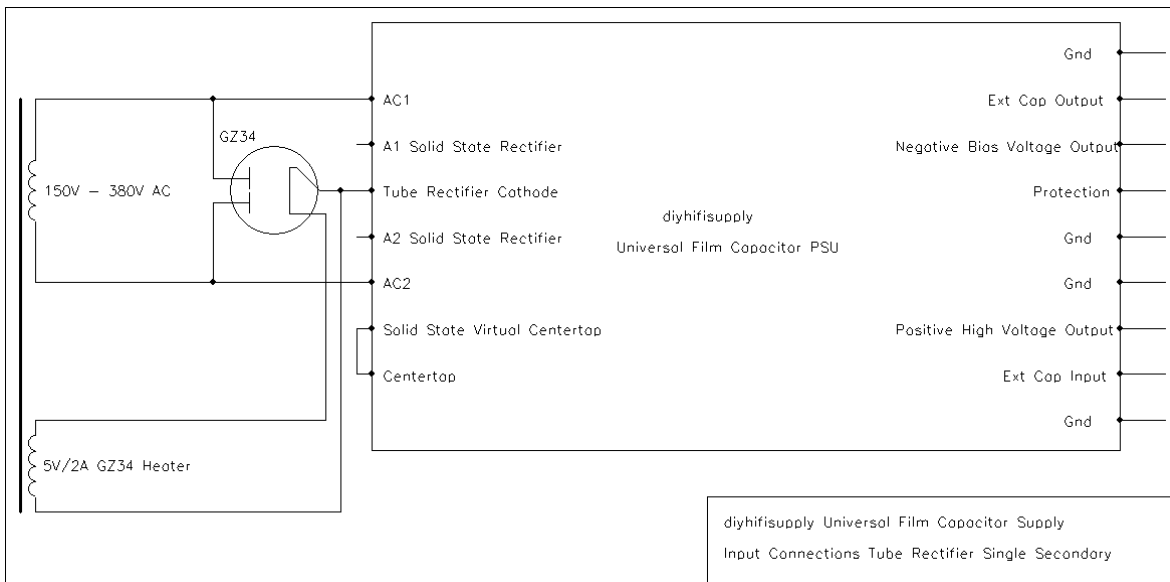

Universal Film Capacitor Power Supply Installation Manual

If a center tap is present on the mains transformer but the on board rectification is to be used, the following scheme must be employed:

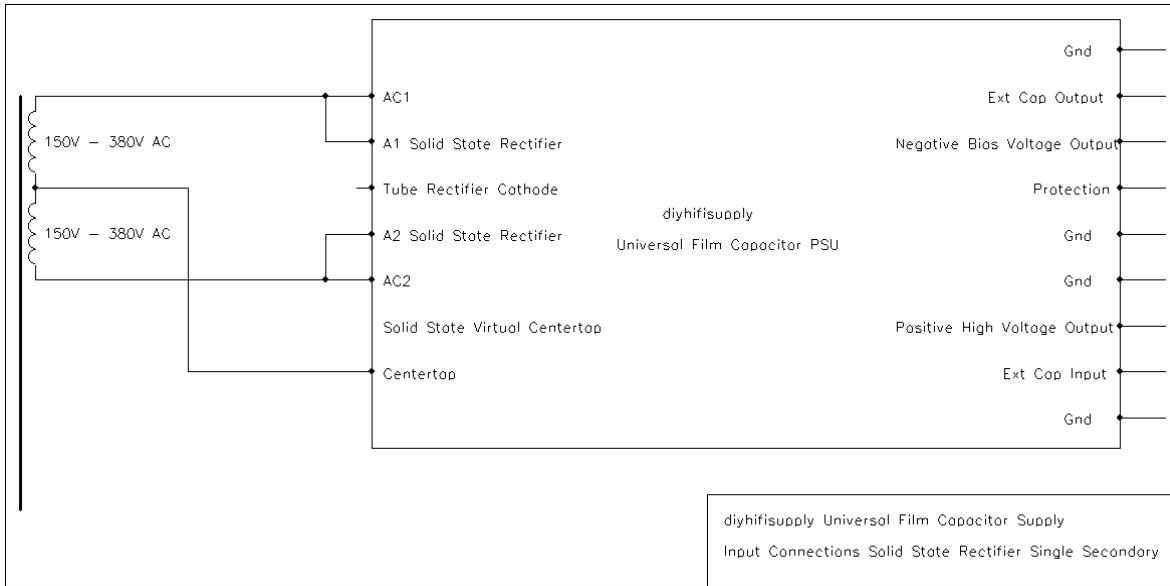

Again it is possible to wire a tube rectifier into the above scheme, the result is a output voltage that is lower, by around 10 – 20%. In this case use the scheme shown below.

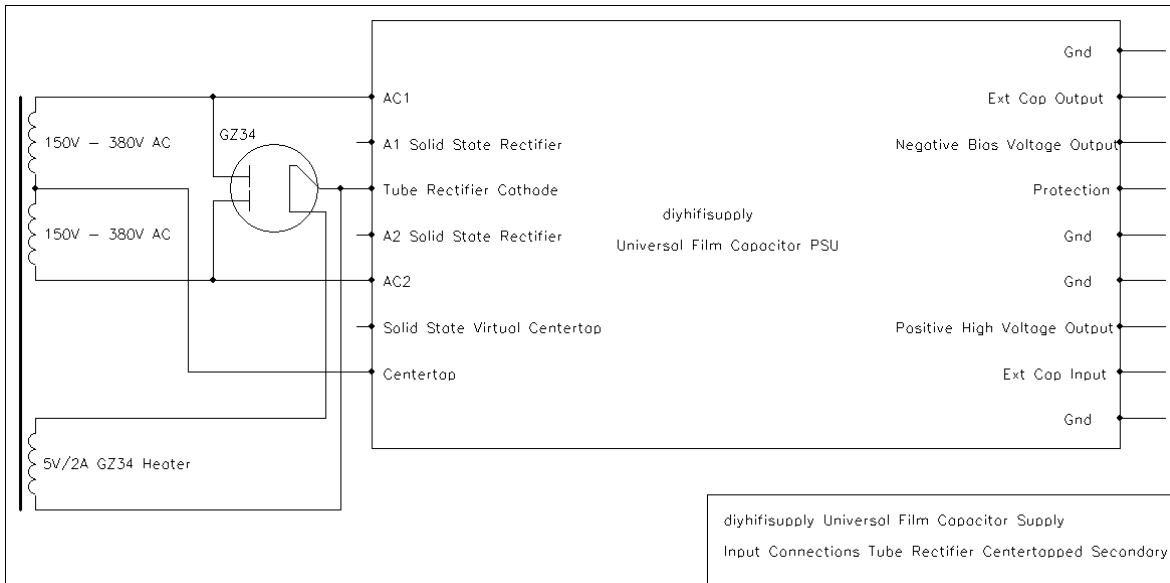

Universal Film Capacitor Power Supply Installation Manual

2 – Output Connections

The Universal Film Capacitor Power Supply was designed to be used with the diyhfisupply® Active Bias Supply Module. It provides the necessary negative high voltage supply for the bias and allows for a “fault” signal to be send back from the Active Bias Supply Module which will shut down the HT supply in case of an output tube that cannot be biased correctly.

This protection circuit is NOT suited for use as “standby” switch!!!!

In this case the connections need to be made as shown below.

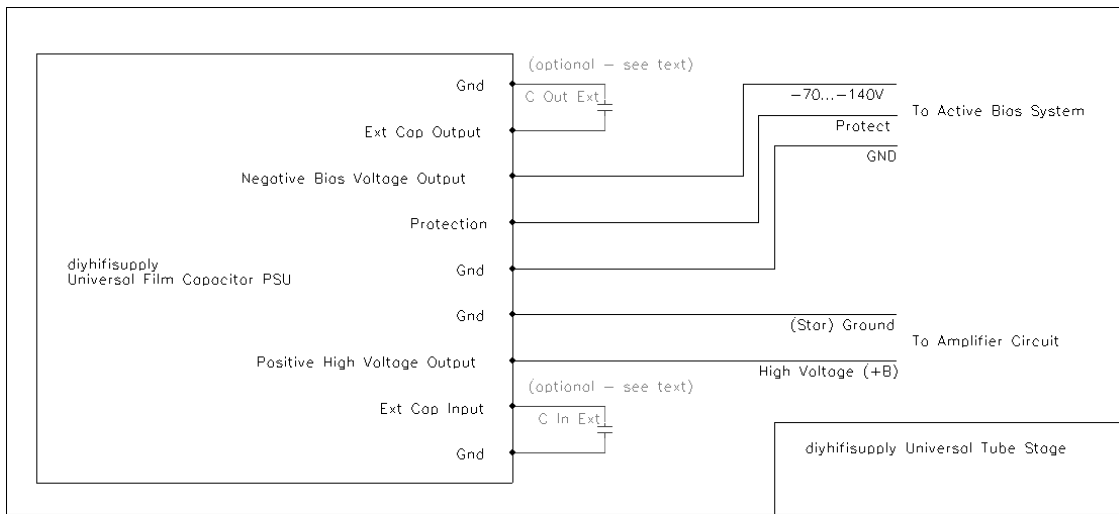

Alternatively the Universal Film Capacitor Power Supply can be use with traditional “manual adjusted” bias. The combined load resistance between the –C terminal and ground should not be lower than 10KOhm.

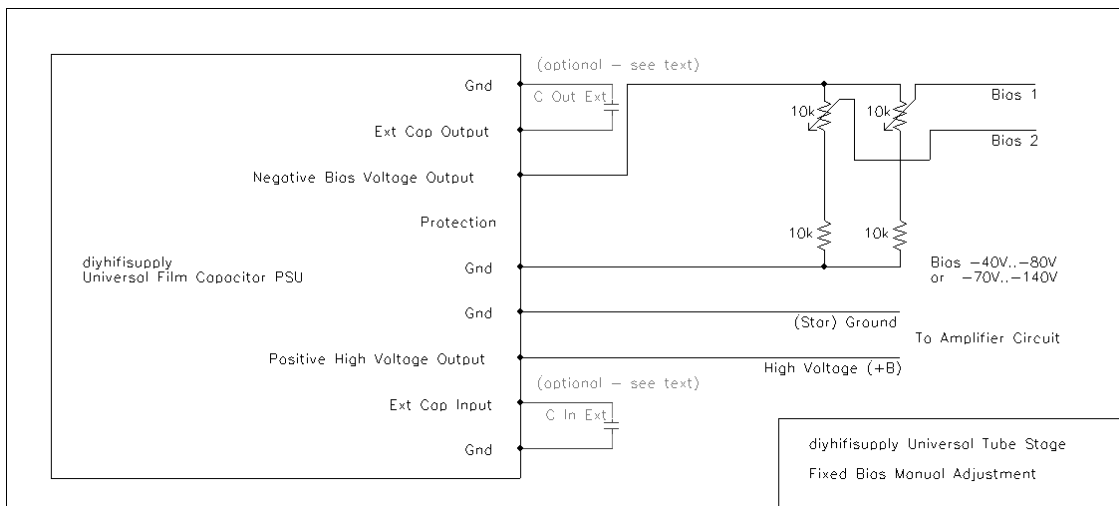

Universal Film Capacitor Power Supply Installation Manual

There are many possible configurations for the biasing network. The ones shown overleaf and here all allow the Bias to be adjusted between the voltage at the -C terminal and around ½ this voltage. If this is not suitable the bias network needs to be adjusted to suit.

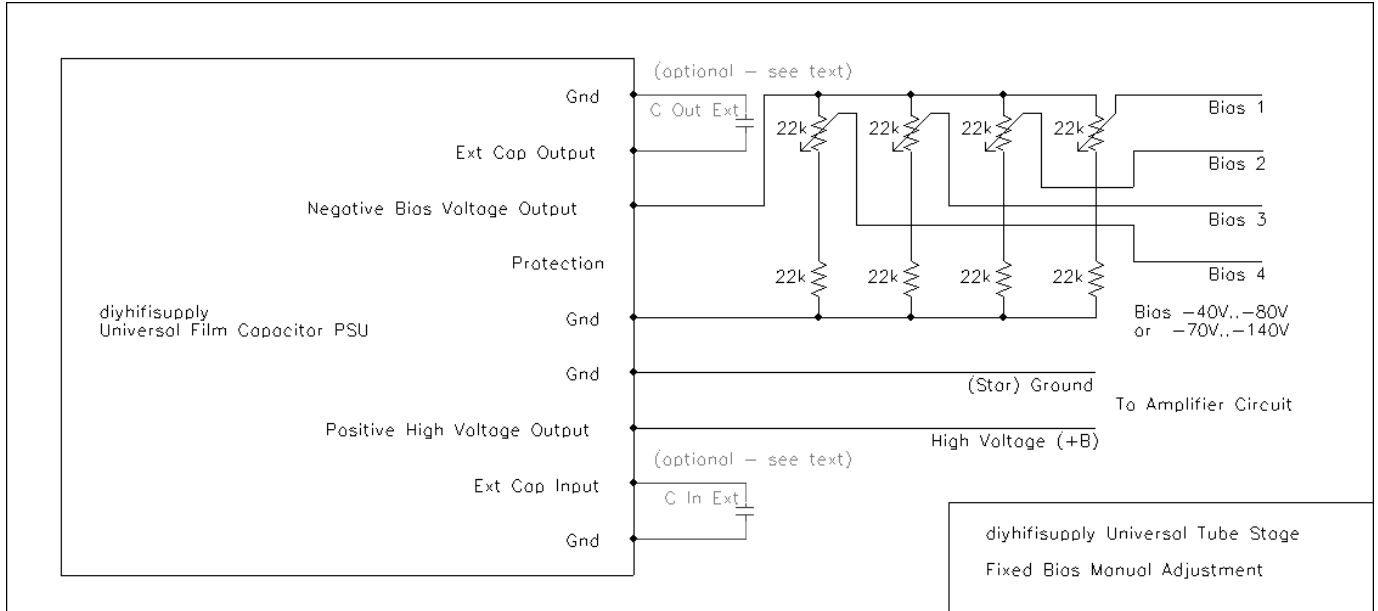

Notes: J1 and J2 jumper settings The "1" Pin is marked by a square solder pad, for both jumpers. It is the pin towards the Heatsinks of the transistors.

J1 selects 80/140V Bias voltage, 1-2 -140V Bias / 2-3 -80V Bias

J2 selects Virtual battery/Choke, 1-2 Virtual Battery / 2-3 Virtual Choke

The Virtual Battery Mode is "default" and requires no external capacitors. It in essence simulates a very low impedance power supply electronically (reference also to LothX PSU).

It must be used if no external capacitors are present.

If you can have a significant value of high quality capacitors (Film etc.) after the Module the "Virtual Choke" is a better choice, as it does not send the amplifier's current back into the secondary and mains transformer, it in essence forces this current into the capacitor.

Universal Film Capacitor Power Supply Installation Manual

3 – Putting it all together

In the following will be presented a few examples of how one may employ the Universal Film Capacitor Power Supply.

Shown first are two SE amplifiers, one with 300B output tubes and one using 2A3 output tubes.

Despite their apparent simplicity and ease of building (due to the availability of various pre-build modules), both make extensive use of advanced design techniques. The use of current source loading for the driver triodes maximises their linearity. The use of grid chokes for the output tube grids improves overload behaviour and bandwidth. And finally reliable fixed bias design eliminates the normally required cathode resistor & capacitor combination, which has sonically detrimental effects.

Combined with state of the art power supplies for the Anodes (and in case of the 300B Amplifier also the heaters) these amplifiers will be limited in performance by the quality of the remaining capacitors in the circuit (all of which can be film or paper/oil types) and the output transformer.

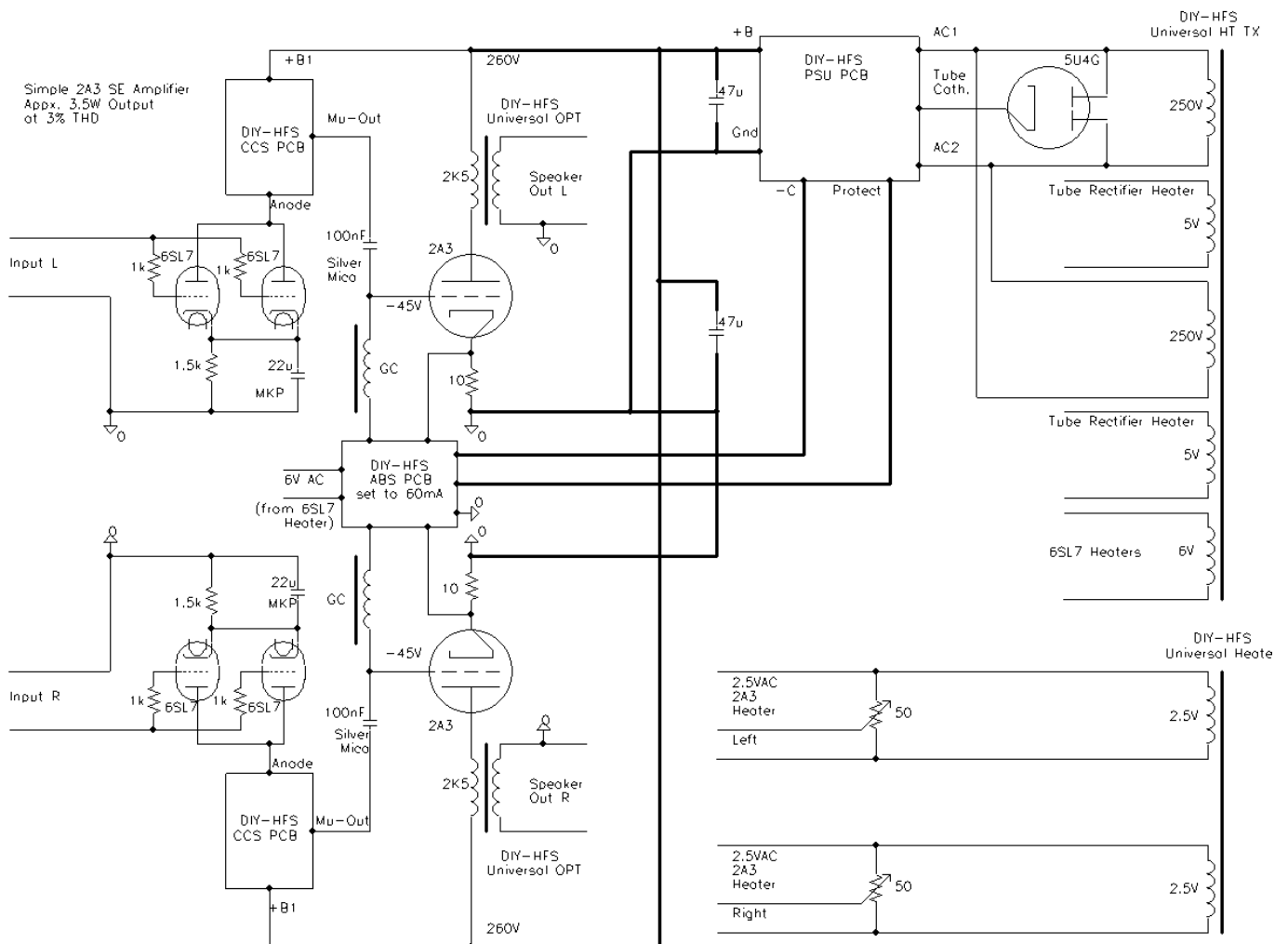

Universal Film Capacitor Power Supply Installation Manual

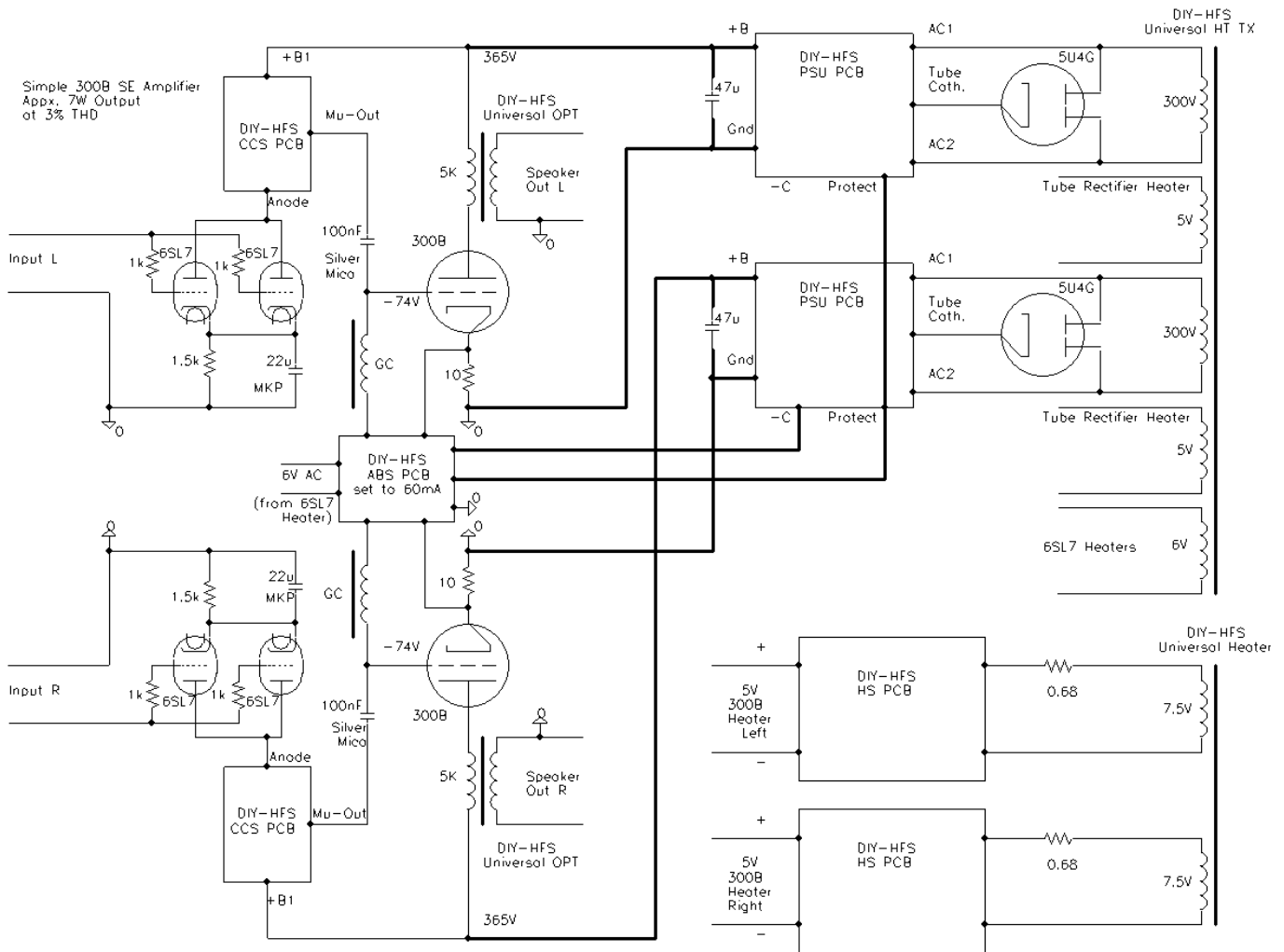

When building the above amplifiers care should be taken to observe the usual safety precautions etc.

The Universal Film Capacitor Power Supply modules should be set to “virtual choke” mode if the additional 47uF film capacitors are used for the +B lines. (J2 selects Virtual battery/Choke, 1-2 Virtual Battery / 2-3 Virtual Choke)

The Bias Voltage for the 2A3 Amplifier should be set to 80V and for the 300B it should be set to 140V. (J1 selects 80/140V Bias voltage, 1-2 -140V Bias / 2-3 -80V Bias)

The current sources need to be adjusted to give around 150V Anode voltage on the 6SL7 for the 2A3 amplifier while for the 300B Amplifier the anode voltage needs to be set to around 230V. Other triodes may be used as input / driver triodes if the cathode RC network is adjusted as needed and the current source is adjusted suitably.

While the Diagrams show diyhifisupply® transformers, other transformers with comparable ratings may be used.

Universal Film Capacitor Power Supply Installation Manual

The following example shows the use of the Universal Film Capacitor Power Supply in a preamplifier application. This is a simple balanced line stage.

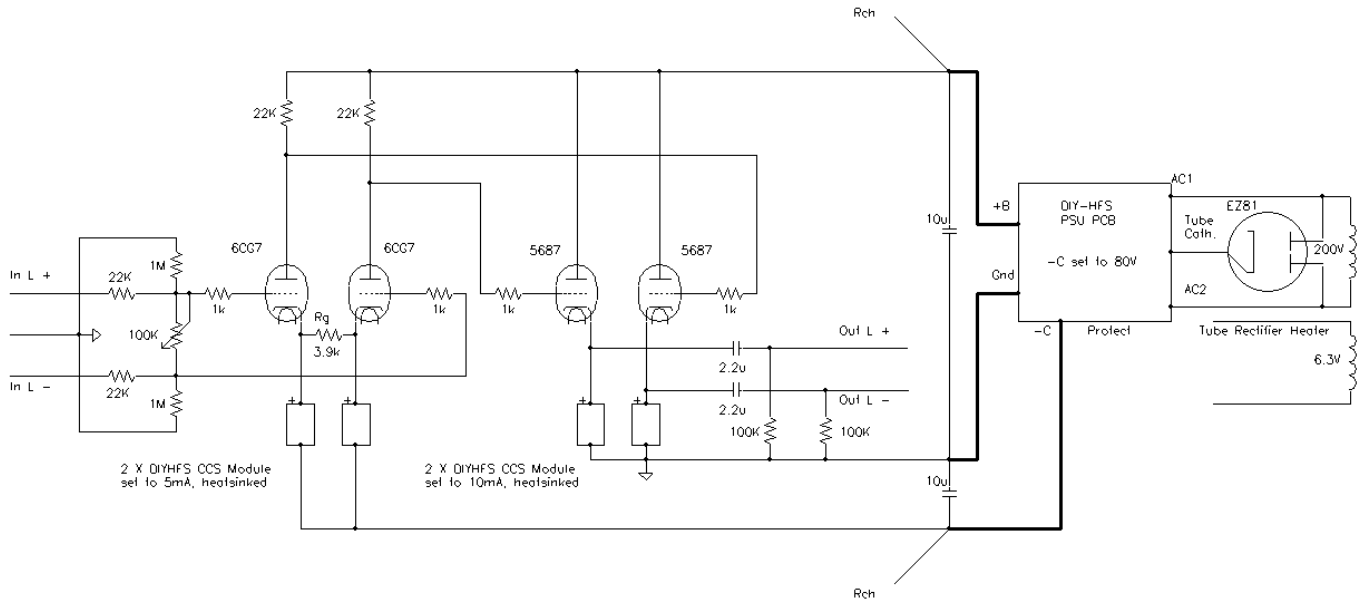

Paramount for the performance of this circuit are the current sources which assure correct balance (input stage) and an optimal loading (output stage). In combination with the exceptional noise performance of the Universal Film Capacitor Power Supply a very simple and elegant circuit can provide state of the art performance.

As shown the gain of this circuit is around 18db. Increasing the resistor marked Rg lowers the gain as required and reducing it can produce slightly more gain, up to around 22db.

If desired a 6SN7, 6N30 or ECC99 may be used instead of the 5687. The 6CG7 may be replaced by a 6SN7, 6922, 6N30, ECC82, ECC99 and many other suitable tubes. It must be noted that in many cases the pin out of the tubes differs and thus in most cases a direct "plug and play" substitution is not possible.