

Mounting instructions for:

XO2 and XO3: low jitter CD clock oscillators

Congratulations! You just bought a high quality, low jitter master clock oscillator. This document gives guidance to mounting and connecting it in your CD player.

Introduction

XO2 and XO3 are equal, except the reclocking option for XO3.

XO2 and XO3

- Need to be supplied from a DC voltage of 9 to 35V, approximately 30mA.
- Generate a new clock, which needs to be fed to the input of the original oscillator

XO3 additionally needs:

- to be fed with the original SPDIF signal (generated by the decoder chip)
- the newly generated SPDIF signal to be connected to the original, or new digital output

Mounting

Mounting your XO is not that difficult. However some experience is needed to:

- recognise and locate components
- find specific connections and IC pin numbers
- measure voltages using a multimeter
- careful soldering of small parts

If you feel lack of skills and or experience in some of the above listed subjects, please ask someone else to support you.

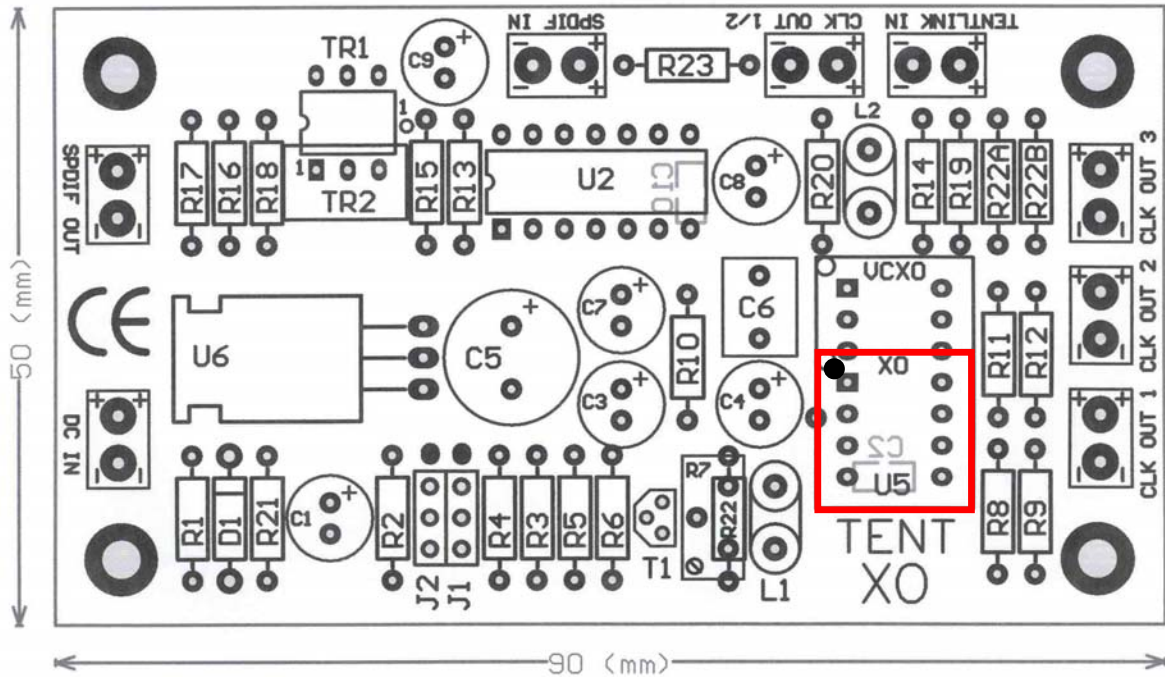

Please note placement of the XO module on the board, indicated by the red border and the dot. Since the new boards are enhanced with Tenta-link (to operate in conjunction with XO-DAC) a bigger socket was required, to accommodate the VCXO. Please read on to know more about the XO DAC options (yet to be written, by this date January 8, 2003, Guido).

The supply and SPDIF in (XO3 only) and clock out (XO2 and XO3) are already equipped with wiring. The supply wire may be extended using normal gauge wire, the others may **not**. If longer wiring is required, the use of coax is advised. Please contact me.

Guido Tent can be contacted for questions and orders at: evaguido@iae.nl

How to connect XO2 or XO3 in your player

General

Read these full instructions below, before starting any work. This will give you a better overview of what you can expect.

Unplug the player from the mains, and open the cabinet. Make sure you work in a safe environment. Find a suitable place within the player. Best location is closest to the original crystal oscillator, to keep critical wiring short. Locate the board such that it can be securely mounted, eventually using stand-offs in the 3 holes of the PCB (3mm).

ESD

Electro Static Discharge may damage chips or lasers or other sensitive parts inside the CD player. Below follow some preventive measures:

- Connect the ground of your soldering iron to the player cabinet or ground or
- Connect the player to safety earth via a series resistor (100k Ω) if the soldering iron is connected to safety earth
- Some shoes and or chairs are very good at helping you to get charged. Avoid these!
- Always touch the metal cabinet and or PCB ground first, when touching (hand) or soldering (iron tip) parts inside your player.

Disclaimer

I cannot be hold responsible for any damage that may appear to your CD player, due to the installation of the XO modules. In addition, warranty of the player may be void due to installing an XO.

Warrantee

All XO modules carry a **5-year** warrantee, assumed that they are built in according these instructions.

Preparation

The connections will be made in the following order:

XO2

1. Clock (black and purple)
2. Power supply + (red)

XO3

1. Clock (black and purple)
2. Power supply + (red)
3. SPDIF (black and yellow)

Crystal clock location

First the original crystal needs to be found. Look for a circuit that is similar to the ones shown right.

It is possible small components are located at the other side of the PCB.



Clock out (XO2 & XO3 both)

Remove crystal and 1 or 2 accompanying capacitors (often both around 22pF).

Connect "clock out" from the XO2/3 PCB with the black and purple wires, as shown right.

The table on page 6 lists input pins from various servo chips.

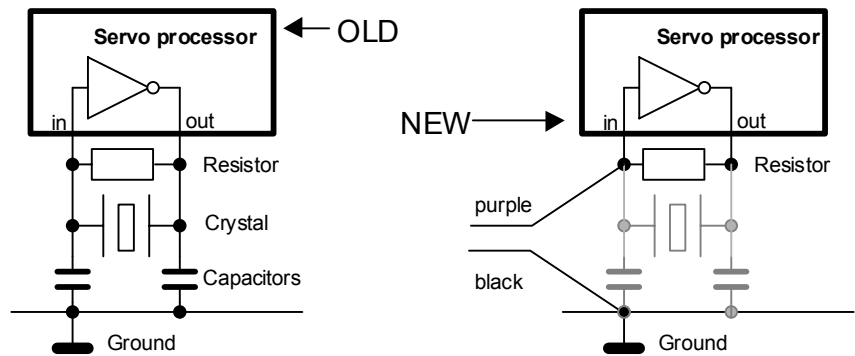

Chip pin location

To locate the pins listed on page 6, the drawing below may be of help.

As a general rule, pin 1 is located down left, when the chip is laid down at the table, and the text is readable.

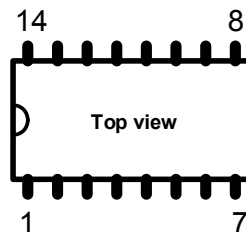

DIL package

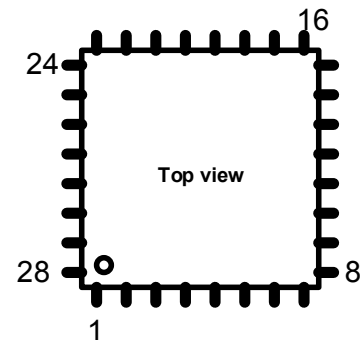

QFP package

Note

If you cannot locate in and output from the oscillator, you may use this method*. Solder 2 resistors (each 10kΩ to 1MΩ) instead of both capacitors. Now switch on the power and measure the DC voltages on both input and output of the oscillator. The pin that reads about 3,3V or 5V is the output, the pin close to 0V is the input. *Courtesy of Elso Kwak.

Power supply (XO2 & XO3 both)

A suitable power supply can be found inside any player. A voltage of around 10 or 12V is often present to feed servo circuits. Mostly it can be found close to the power supply capacitors, sometimes at a separate PCB. Check the appropriate voltage with a multimeter.

Connect the black wire of the multimeter to the ground (e.g. the screen of the analogue output RCA connector). Now switch the multimeter to 200Vdc range and locate the required voltage inside the player with the red probe.

Now connect the red (+) wire to the point you located above. Route the wire neatly away, taking care of all possible movements from the drive (sledge, tray, spindle)

Now the CD player can be checked. In the case of mounting XO3, you may continue below.

SPDIF in (XO3 only)

The original SPDIF output is mostly present at an output pin of the decoder chip. 2 options are available:

1. **Maintain** original SPDIF output and add improved SPDIF output
2. **Replace** the existing SPDIF output for new improved output

For both options, the SPDIF output pin needs to be derived from the table at page 5

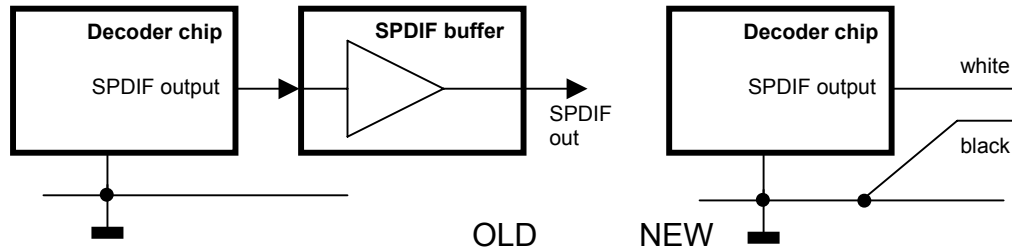

1. Maintain original SPDIF output and add improved SPDIF output

Tap the signal in-between the decoder and the buffer, and feed it to "SPDIF in" (XO3 board), by means of the black and white wires. Connect the black wire to a ground pin closest to the SPDIF output pin.

Connect either an RCA or a BNC chassis connector (not supplied) to connection SPDIFout on the XO PCB. The connector can be mounted at the back of the CD player. Therefore it is necessary to drill a new hole in the back of that cabinet. Use twisted wire (< 15 cm) or coaxial cable (75 ohm) for longer connections. Connect the ground of the connector to "-", and the centre wire to "+".

2. Replace the existing SPDIF output for a new improved output

Interrupt the signal in-between the decoder and the buffer, and feed it to "SPDIF in" (XO3 board), by means of the black and white wires. Connect the black wire to a ground pin closest to the SPDIF output pin.

Now locate the original RCA socket and make sure that all original connections to are interrupted. Wire a pair of twisted wires from SPDIF out to that connector. If the length of about 15cm is exceeded, use 75Ω coaxial cable instead.

Problem solving FAQ

Q I installed the XO but after power up the disc does not spin

A It is very likely that your player does not receive the new clock

- Check if the power supply at the input of XO2/3 PCB is present when the player is powered up
- Check if the 2 jumpers J2/3 are present (should be at the inner positions)
- Check if the outgoing clock is fed to the input of the decoder / servo chip
- Measure if the clock is present at that position (oscilloscope required)

Q I installed XO3, but my DAC does not lock onto the new SPDIF output

A It is very likely that XO3 does not receive the original SPDIF signal from your player

- Verify if the SPDIF is present at the XO3 input (oscilloscope required)
- Check if the reclocked SPDIF is present at pin 6 of the IC

Pinning list for commonly used servo and decoder chips

Servo Type Input # Frequency [MHz]

Sony

CDX1125(Q)	53	often 16,9344
CDX2500	53	often 16,9344
CDX25008	53	often 16,9344

Philips

SAA7220	11	often 11.2896
SAA7246	71	often 11.2896
SAA7310	26	often 11.2896
SAA7322/23	25	often 11.2896
SAA7345	13	16,9344 or 33.8688
SAA7350	14	11.2896 or 16.9344
SAA7370	21	8.4672, 16,9344 or 33.8688
SAA7372	21	8.4672, 16,9344 or 33.8688
SAA7374	21	8.4672, 16,9344 or 33.8688
SAA7376	21	8.4672, 16,9344 or 33.8688
SAA7378	21	8.4672, 16,9344 or 33.8688

NPC

SM5803	6	16,9344 or 33.8688
SM5813	6	16,9344 or 33.8688 (DIL package)
SM5872BS	28	16,9344 or 33.8688 (DIL package)

Various

M50423P	70	8.4672
MN6471M	25	33.8688

Update

I appreciate if you contribute to keep this list updated. If you find any new chips, or wrong indications from my side, please let me know.

Decoder Type	SPDIF Ouput pin	Decoder Type	SPDIF Ouput pin
Sony			
CXD1125QX	5	M50422P	15
CXD1130QZ	5	M50423FP	17
CXD1135	5	M50427FP	5
CXD1167Q	5	M65820	17
CXD1167R	39	MN6617	74
CXD2500AQ/BQ	24	MN6625S	41
CXD2505AQ	24	MN6626	3
CXD2507AQ	39	MN66271	52?
CXD2508AQ	34	MN662720RB	44
CXD2515Q	36		
CXD2518Q	36		
		Philips	
HD49215	5	SAA7220	14
		SAA7310	32
		SAA7345	8
KS9282	5	SAA7341	36
KS911B	5		
KS9212	5	TC9200AF	?
KS5990	5	TC9221F	60
KS5991	5	TC9236AF	56
LC7860/1(N,K)	8	VPD6375CU	46
LC7863	8		
LC7865	?		
LC7866/7/8E	8	Yamaha	
LC78622E	45	YM2201FK	?
LC78681	8	YM3805	8
		YM7121B	7

Update

I appreciate your contribution to keep this list updated. If you find any new chips, or wrong indications from my side, please let me know.